

RI/RD90-149-5

P-51

(NASA-CR-188754) OPERATIONALLY EFFICIENT
PROPULSION SYSTEM STUDY (OEPSS) DATA BOOK
Interim Report, Apr. 1989 - Apr. 1990
(Rockwell International Corp.) 51 pCSCL 14B

N92-19524

Unclas

63/14 0036874

OPERATIONALLY EFFICIENT PROPULSION SYSTEM STUDY (OEPSS) DATA BOOK

Executive Summary

**Prepared for
Kennedy Space Center
NAS10-11568**

**Prepared by
George S. Wong**

April 24, 1990

**Rocketdyne Study Managers: G. S. Wong/G. S. Waldrop
NASA, KSC Study Manager: R. E. Rhodes**

**Rockwell International
Rocketdyne Division
6633 Canoga Avenue
Canoga Park, CA 91303**

Report Documentation Page

1. Report No.	2. Government Accession No.	3. Recipient's Catalog No.	
4. Title and Subtitle Operationally Efficient Propulsion System Study (OEPSS) - Data Book: Executive Summary		5. Report Date April 24, 1990	
		6. Performing Organization Code	
7. Author(s) George S. Wong		8. Performing Organization Report No. RI/RD90-149-1,2,3,4,5	
		10. Work Unit No.	
9. Performing Organization Name and Address Rocketdyne Division, Rockwell International Corporation 6633 Canoga Ave. Canoga Park, CA 91303		11. Contract or Grant No. NAS10-11568	
		13. Type of Report and Period Covered Interim Report; April 1989-April 1990	
12. Sponsoring Agency Name and Address National Aeronautics and Space Administration, John F. Kennedy Space Center, Kennedy Space Center, Florida 32899		14. Sponsoring Agency Code	
		15. Supplementary Notes Study conducted under ALS/ADP5103 Contract Technical Monitor: Russel E. Rhodes Co-author Organizations: Raymond J. Byrd, Boeing Aerospace Operations; James M. Ziese, Space Systems Division, Rockwell International	
16. Abstract This study was initiated to identify operations problems and cost drivers for current propulsion systems and to identify technology and design approaches to increase the operational efficiency and reduce operations costs for future propulsion systems. To provide readily usable data for the ALS program, the results of the OEPSS study have been organized into a series of OEPSS Data Books as follows: Volume I, Generic Ground Operations Data; Volume II, Ground Operations Problems; Volume III, Operations Technology; Volume IV, OEPSS Design Concepts; and Volume V, OEPSS Final Review Briefing, which summarizes the activities and results of the study. This executive volume summarizes the salient results of the first year, and a synopsis of each volume listed above is presented.			
17. Key Words (Suggested by Author(s)) Launch operations, integrated design, propulsion system, propellant tanks, launch vehicle, air-augmented rocket, operations technology, ejector/rocket		18. Distribution Statement Unclassified -- unlimited	
19. Security Classif. (of this report) Unclassified	20. Security Classif. (of this page) Unclassified	21. No. of pages 28	22. Price

FOREWORD

This document is part of the final report for the Operationally Efficient Propulsion System Study (OEPSS) conducted by Rocketdyne Division, Rockwell International for the AFSSD/NASA ALS Program. The study was conducted under NASA contract NAS10-11568 and the NASA Study Manager is Mr. R. E. Rhodes. The initial OEPSS program manager was Arthur H. Weiss; he was followed by Donald L. Fulton, who was program manager for OEPSS and ALS STEP. The period of study was from 24 April 1989 to 24 April 1990.

ABSTRACT

This study was initiated to identify operations problems and cost drivers for current propulsion systems and to identify technology and design approaches to increase the operational efficiency and reduce operations cost for future propulsion systems. To provide readily useable data for the ALS program, the results of the OEPSS study have been organized into a series of OEPSS Data Books as follows: Volume I, Generic Ground Operations Data; Volume II, Ground Operations Problems; Volume III, Operations Technology; Volume IV, OEPSS Design Concepts; and Volume V, OEPSS Final Review Briefing, which summarizes the activities and results of the study.

ACKNOWLEDGMENT

The author wishes to express sincere thanks to the OEPSS Team for their excellent cooperation and support: Messrs. Raymond J. Byrd, Boeing Aerospace Operations; James M. Ziese, SSD Rockwell International; and J. O. Vilja, Rocketdyne. Special thanks is extended to the Deputy Study Manager, Mr. Glen S. Waldrop, Launch Operations, Rocketdyne, for his dedicated efforts, enthusiastic support, and invaluable expertise given to the study. The response and encouragement received from the ALS program, NASA/AF centers, and NASA Headquarters are greatly appreciated. The cooperation received from CCAFC launch site personnel is also gratefully appreciated: Messrs. Ken Branch, General Dynamics, Space Systems Company; Andy Haupt, McDonnell Douglas, Space Systems Company; and William Case, Martin Marietta Corporation. Finally, as a personal note, I found the sincerity, dedication, and leadership shown by Messrs. Russel E. Rhodes and William J. Dickinson, NASA Kennedy Space Center, in the commitment to achieve high operational efficiency in future launch systems, has been for me an immensely rewarding and inspiring experience.

INTRODUCTION

Today's launch operations are excessively complex and unforgiving and launch processing has been tedious and time consuming. As a result, launch operations cost has been uneconomically high and our capability for routine space flight has been severely limited. Therefore, a study was undertaken to identify the major operational problems that have been encountered by propulsion systems in current launch vehicles and to identify how these problems can be avoided in the future to increase the operational efficiency of the next generation of launch systems.

The present Operationally Efficient Propulsion System Study (OEPSS) outlined in Figure 1 is sponsored by the AFSSD/NASA, ALS Program, and directed by NASA Kennedy Space Center. The study followed a previous similar study conducted by Boeing Aerospace Company for NASA Kennedy Space Center entitled, Shuttle Ground Operations Efficiency/Technologies (SGOE/T) Study which identified operational problems for the launch vehicle. The OEPSS study to date has generated ground operations data that should be helpful for designers to assess future designs. The study has also identified: (a) major operational problems and their impact on operational requirements; (b) operations technology that will enhance operability and simplify launch site operations and support requirements; and (c) illustrative design approaches that will achieve operability and, consequently, operational efficiency in future propulsion designs.

The results of the OEPSS study have been widely disseminated in briefings, workshops, symposiums, and ALS Propulsion System Interface Working Group (PSIWG) meetings. These activities are shown in Figure 2. The on-site workshops with the ALS study contractors were particularly effective means of communicating and discussing operations issues and their impact on design. A series of OEPSS Data Books also have been prepared and distributed summarizing the results of the OEPSS study.

The key to operational efficiency is to achieve operability in the propulsion system design. This means future designs must be simpler than those we have today. This in turn means the total propulsion system must be reduced to fewer parts, components, subsystems, and system interfaces. Achieving this, together with enhancing technology, results in a more operable system. With operability, it is axiomatic that all the ALS goals for reliability, dependability, supportability, flexibility, availability, and resiliency will follow and be more easily met. It is also a truism that a complex design will have complex operational requirements and a simple design, with the fewest parts, will be more reliable and will have simple operational requirements.

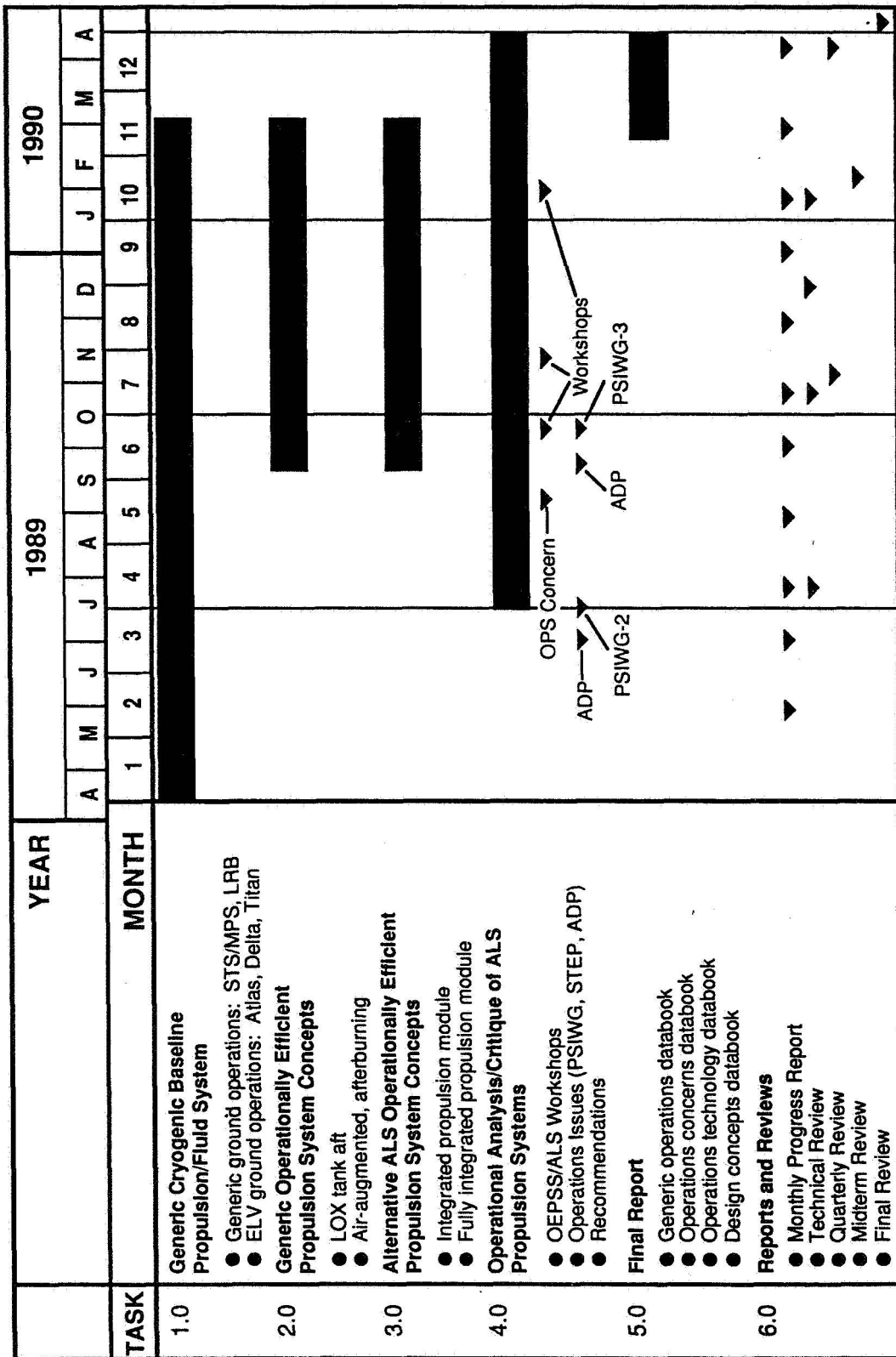

Figure 1. OEPSS Study Schedule

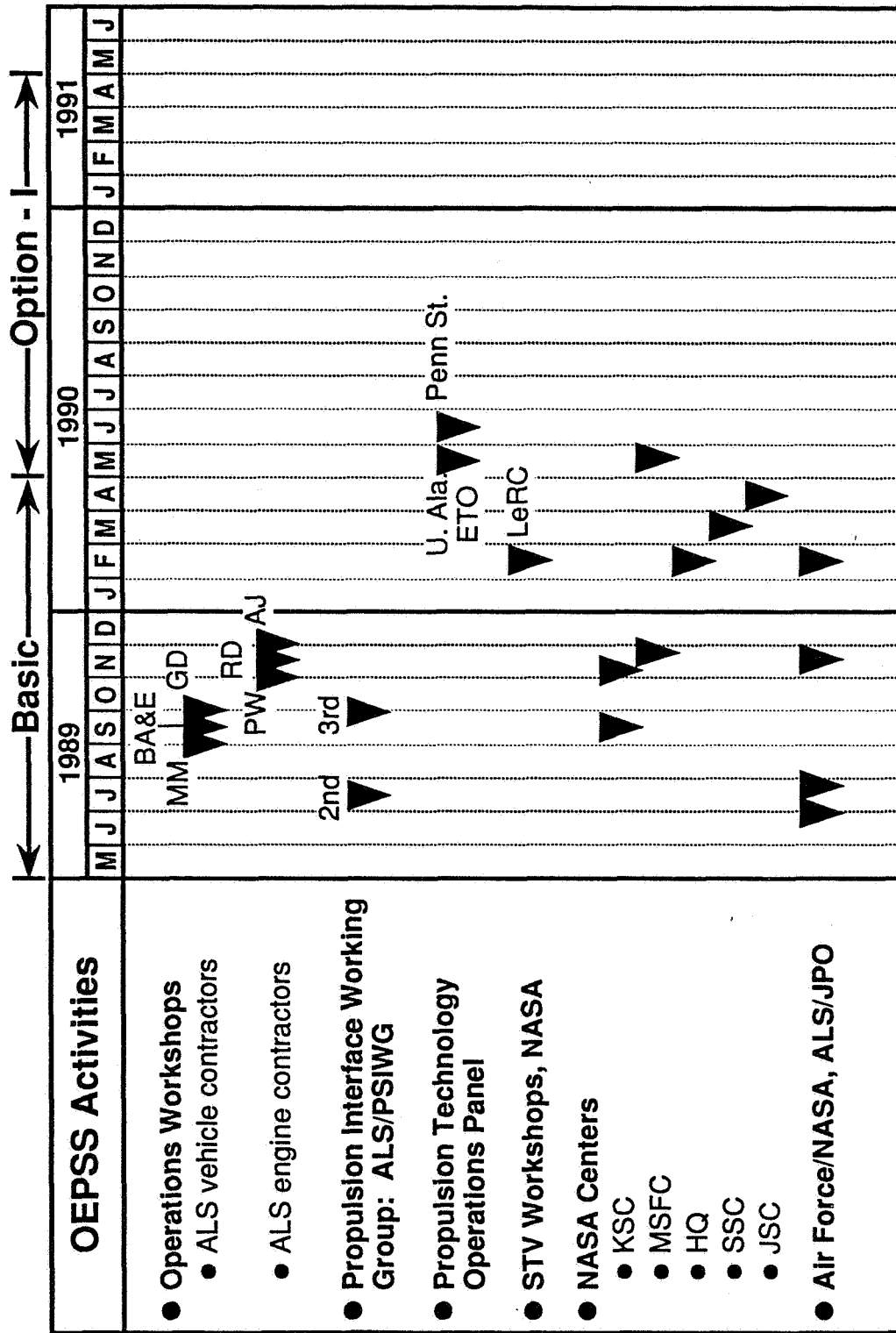

Figure 2. OEPSS Interaction With Design Community

CONTENTS

1.0	GENERIC GROUND OPERATIONS DATA (VOLUME I)	1-1
2.0	GROUND OPERATIONS PROBLEMS (VOLUME II)	2-1
3.0	OPERATIONS TECHNOLOGY (VOLUME III)	3-1
4.0	OEPSS DESIGN CONCEPTS (VOLUME IV)	4-1
4.1	FULLY INTEGRATED PROPULSION CONCEPT	4-1
4.2	LOX TANK AFT PROPULSION CONCEPT	4-11
4.3	AIR-AUGMENTED, ROCKET ENGINE NOZZLE AFTERBURNING PROPULSION CONCEPT	4-11
5.0	OEPSS FINAL BRIEFING (VOLUME V)	5-1

TABLES

4-1.	Comparison of Conventional and Integrated Propulsion System Design Features	4-6
4-2.	Integrated Propulsion Systems Synthesized by Engine-Elements	4-10
4-3.	Ejector Design Parameters	4-15

FIGURES

1-1.	OEPSS Generic Launch Vehicle	1-2
1-2.	Launch Operational Requirements	1-3
1-3.	OEPSS Generic Core Vehicle Top Logic Diagram	1-5
1-4.	OEPSS Generic Core Vehicle MPS Logic Diagram	1-6
1-5.	OEPSS Generic Core Vehicle MPS Processing	1-7
1-6.	OEPSS Generic Orbit Vehicle Top Logic Diagram	1-8
1-7.	OEPSS Generic Orbit Vehicle Propulsion System Logic Diagram	1-9
2-1.	Launch System Operations Support	2-2
2-2.	Launch Operations Support Structure	2-3
2-3.	Ground Operations Problems	2-4
3-1.	Operations Technology	3-2
3-2.	Operations Concerns Addressed by Technology	3-3
3-3.	Operations Technology Applied to Future Vehicles	3-4
4-1.	ALS Reference Vehicle	4-2
4-2.	Conventional Booster Propulsion System	4-3
4-3.	Fully Integrated Booster Propulsion Module	4-4
4-4.	Schematic Comparison of Conventional and Integrated Propulsion Systems	4-5
4-5.	Integrated Engine-Element	4-7
4-6.	ALS Integrated Core Propulsion Module	4-8

FIGURES

4-7. Payload Capabilities of Integrated Propulsion Systems	4-9
4-8. Operation Concerns Addressed by Integrated BPM	4-10
4-9. LOX Tank Concepts	4-12
4-10. Rocket Engine Air-Augmented Afterburning Concept	4-15

1.0 GENERIC GROUND OPERATIONS DATA (VOLUME I)

Significant propulsion system ground processing time and manpower data are presented in this volume. The purpose is to allow future system designers to understand the magnitude of resources at the operations and maintenance instruction level necessary to process their design. A generic launch vehicle is used to characterize the flow timelines and manpower required to test, check out, and service the propulsion/fluid system. This generic vehicle is shown as a schematic in Figure 1-1 and consists of an expendable LOX/LH₂ booster, a partially expendable LOX/LH₂ core, and a recoverable hypergolic orbit vehicle. The schematic does not imply any specific physical arrangement (tandem or parallel) but does reflect today's state of art in design practices and ground operations. Generic vehicle launch processing and ground operations are shown in Figure 1-2.

The generic vehicle is intended to provide designers with a baseline with a credible database against which to evaluate new designs. The data is also success-oriented based on experience and not actuals. Much of the data were derived from: shuttle Processing Contracts (SPC) planning and scheduling systems, notably the Computer Aided Planning and Scheduling System (CAPSS), KSC Integrated Operations Assessments, and Operations and Maintenance Instructions (OMIs). Tasks, durations, manpower, and interactive sequence are directly indicative of the complex relationships between vehicle/systems configurations and ground processing requirements. The data for the generic booster was extracted from the liquid Rocket Booster (LRB) Integration study conducted by Lockheed Space Operations Co. (LSOC).

This volume contains nine sections, describing generic vehicle component ground processing as follows:

- | Section | |
|---------|---|
| 3.0 | Generic Booster Ground Operations |
| 4.0 | Generic Core Vehicle Ground Operations |
| 5.0 | Generic Orbit Vehicle Ground Operations |
| 6.0 | Generic Core Tank Ground Operations |
| 7.0 | Generic Core Propulsion Stacking |
| 8.0 | Generic Core Tank Erect and Mate |
| 9.0 | Generic Orbit Vehicle Lift and Mate |
| 10.0 | Vehicle Rollout to Pad and Launch |
| 11.0 | 24-Hour Scrub Turnaround |

GENERIC LOX/LH2 LAUNCH VEHICLE GROUND PROCESSING DATA DEVELOPED

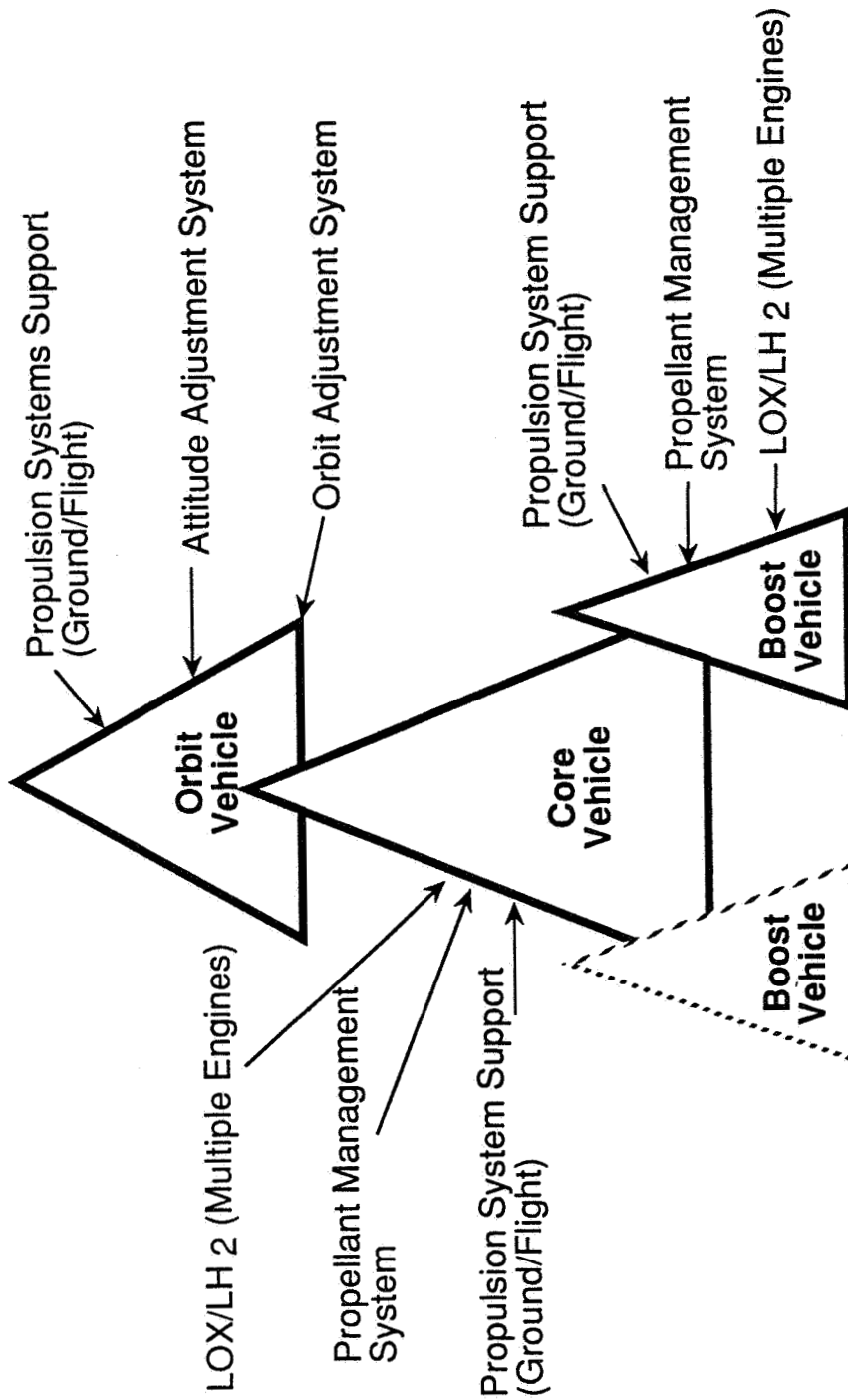

OEPPSS Volume I - Generic Ground Operations

Figure 1-1. OEPPSS Generic Launch Vehicle

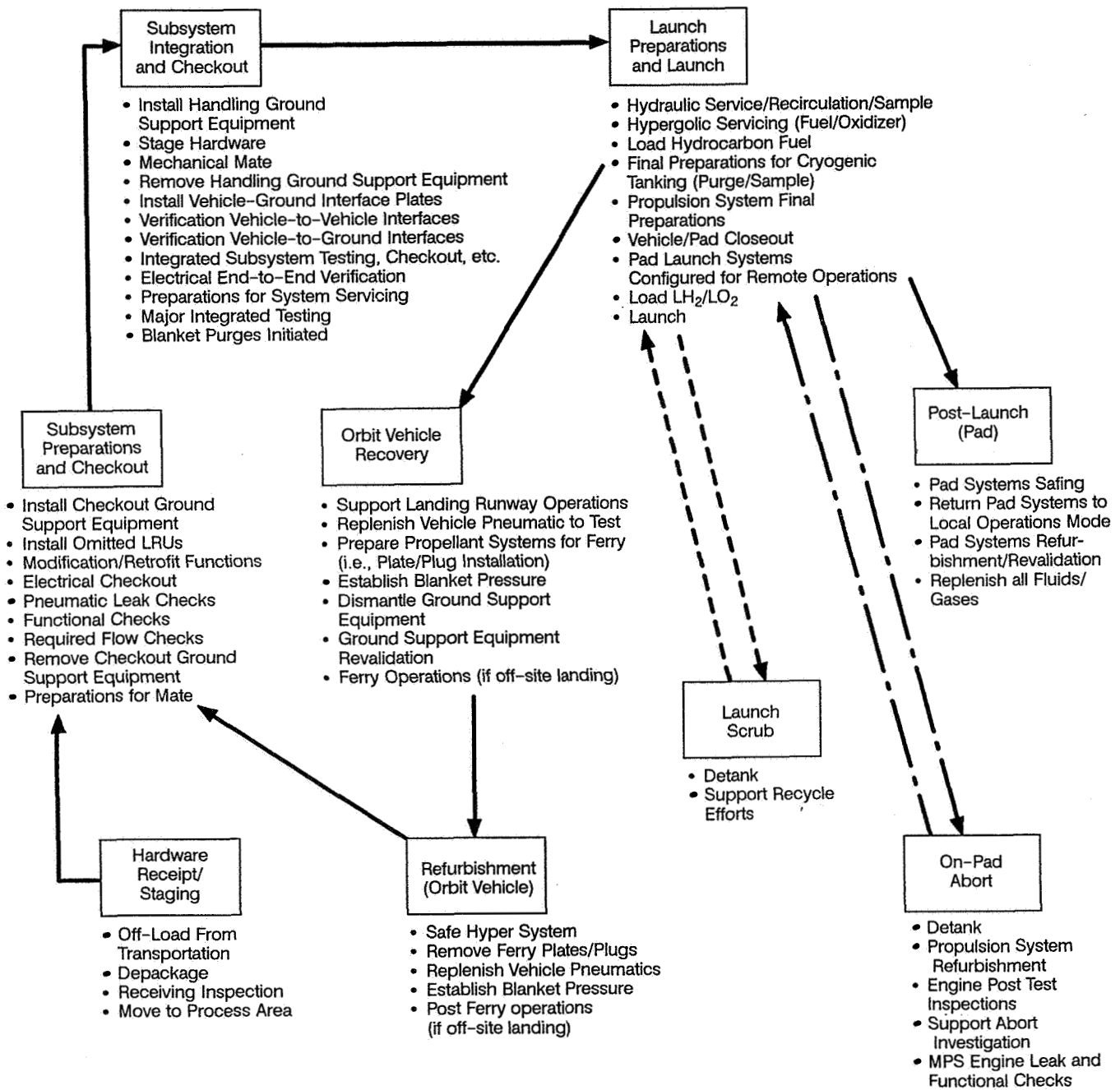

5872-6

Figure 1-2. Launch Operational Requirements

Tabulations and charts that identify ground processing tasks to the operating procedure level, task performance sequence and hierarchy logic diagram, manpower, skill codes, skill mix, and critical path tasks and durations are presented in each of the sections. Some typical data (for the Generic Core and Orbit Vehicles) are shown in Figures 1-3 through 1-7.

Recoverable LOX/LH2 Propulsion System

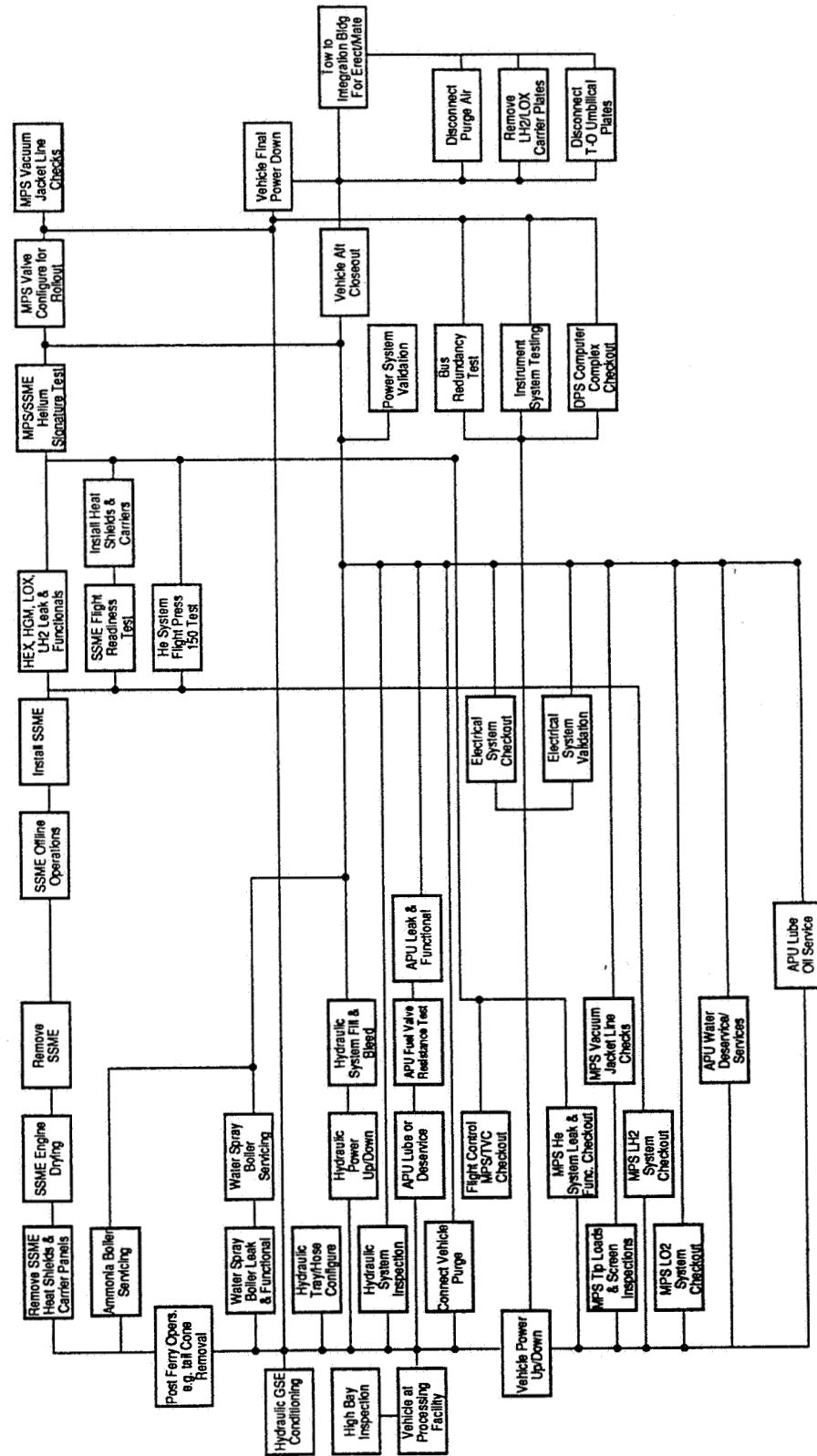

Figure 1-3. OEPSS Generic Core Vehicle Top Logic Diagram

TYPICAL MAIN PROPULSION SYSTEM (MPS) GROUND PROCESSING

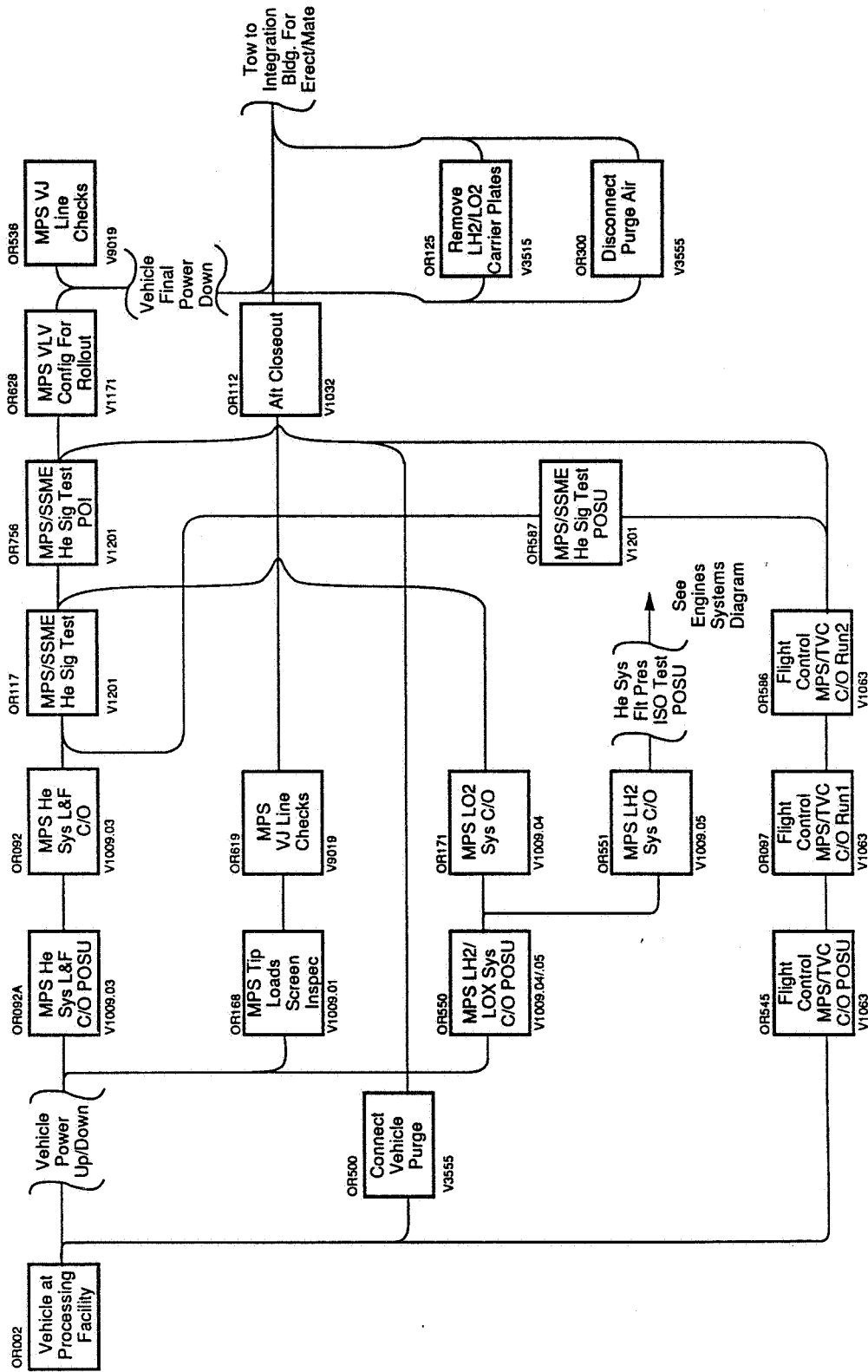

Figure 1-4. OEPSS Generic Core Vehicle MPS Logic Diagram

MAIN PROPULSION SYSTEM PROCESSING ACTIVITY, TIME DURATION AND MANPOWER

Oper.	OMI	Activity	Dur. Hrs.	Head Count	Manhours
OR002	-	Vehicle at Processing Facility	-	-	-
OR092A	V1009.03	MPS He sys. L&F C/O POSU	16	9	144
OR092	V1009.03	MPS He sys. L&F C/O	48	9	432
OR117	V1201	MPS/SSME He sig test	40	11	440
OR756	V1201	MPS/SSME He sig test POI	16	5	80
OR628	V1171	MPS VLV config. for rollout	4	2	8
OR536	V9019	MPS vacuum jacket line checks	8	5	40
OR168	V1009.01	MPS tip loads & screen inspect	56	9	504
OR619	V9019	MPS VJ line checks	8	5	40
OR112	V1032	Aft closeout *	312	15	4680
OR500	V3555	Connect vehicle purge	4	7	28
OR125	V3515	Remove LH2/LO2 carrier plates	4	3	12
OR550	V1009.04/05	MPS LH2/LO2 Sys. C/O POSU	16	8	128
OR171	V1009.04	MPS LO2 sys. C/O	48	8	384
OR587	V1201	MPS/SSME He Sig test POSU	72	7	504
OR300	V3555	Disconnect purge air	4	7	28
OR551	V1009.05	MPS LH2 sys C/O	48	8	384
OR545	V1063	Flight control MPS/TVC C/O POSU	8	4	32
OR097	V1063	Flight control MPS/TVC C/O Run 1	10	4	40
OR586	V1063	Flight control MPS/TVC C/O Run 2	10	4	40
		TOTAL	732		7948

* Aft closeout includes the full spectrum of vehicle activities (not propulsion only)

Figure 1-5. OEPSS Generic Core Vehicle MPS Processing

Reusable Vehicle - Hypergolic Propulsion

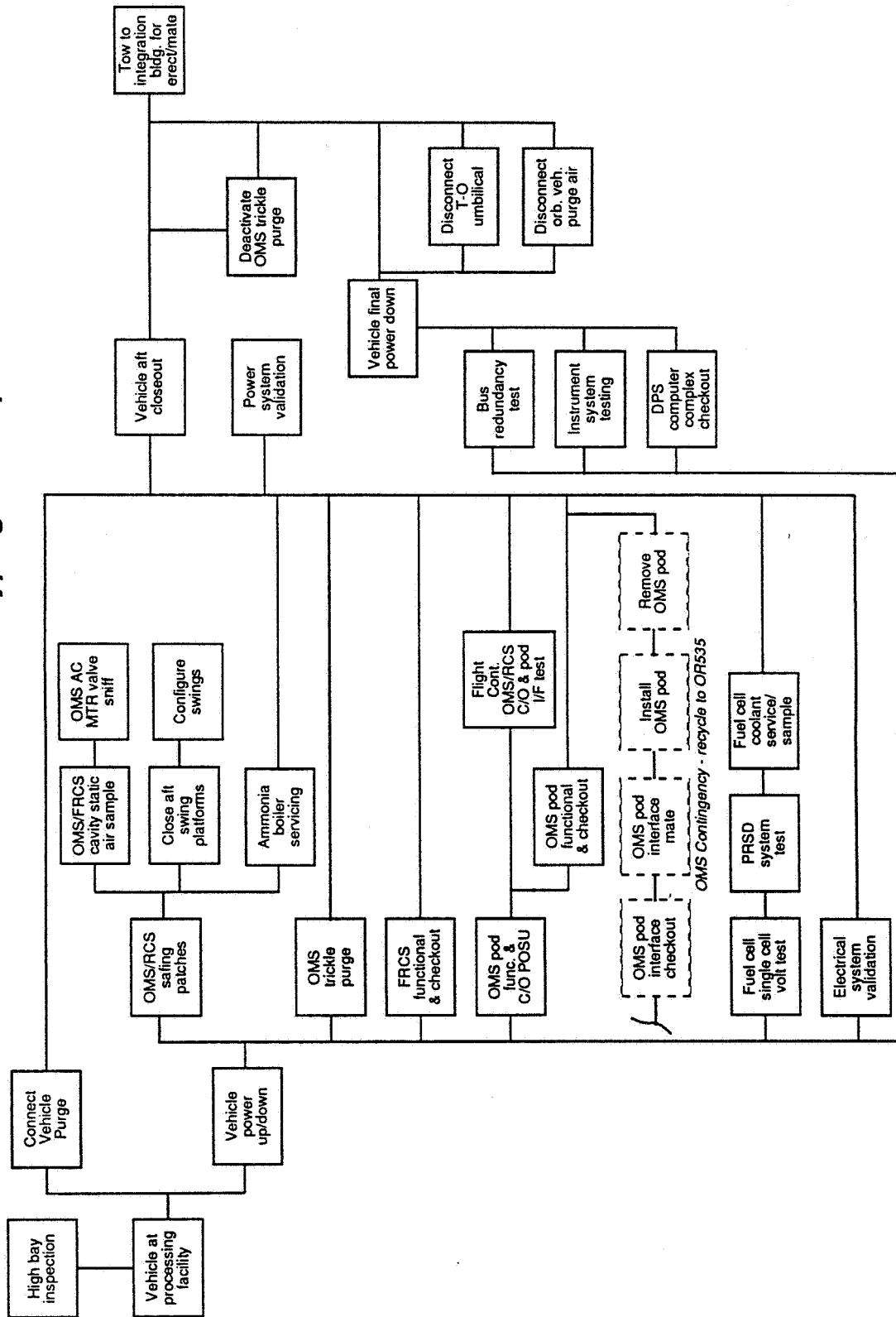

Figure 1-6. OEPSS Generic Orbit Vehicle Top Logic Diagram

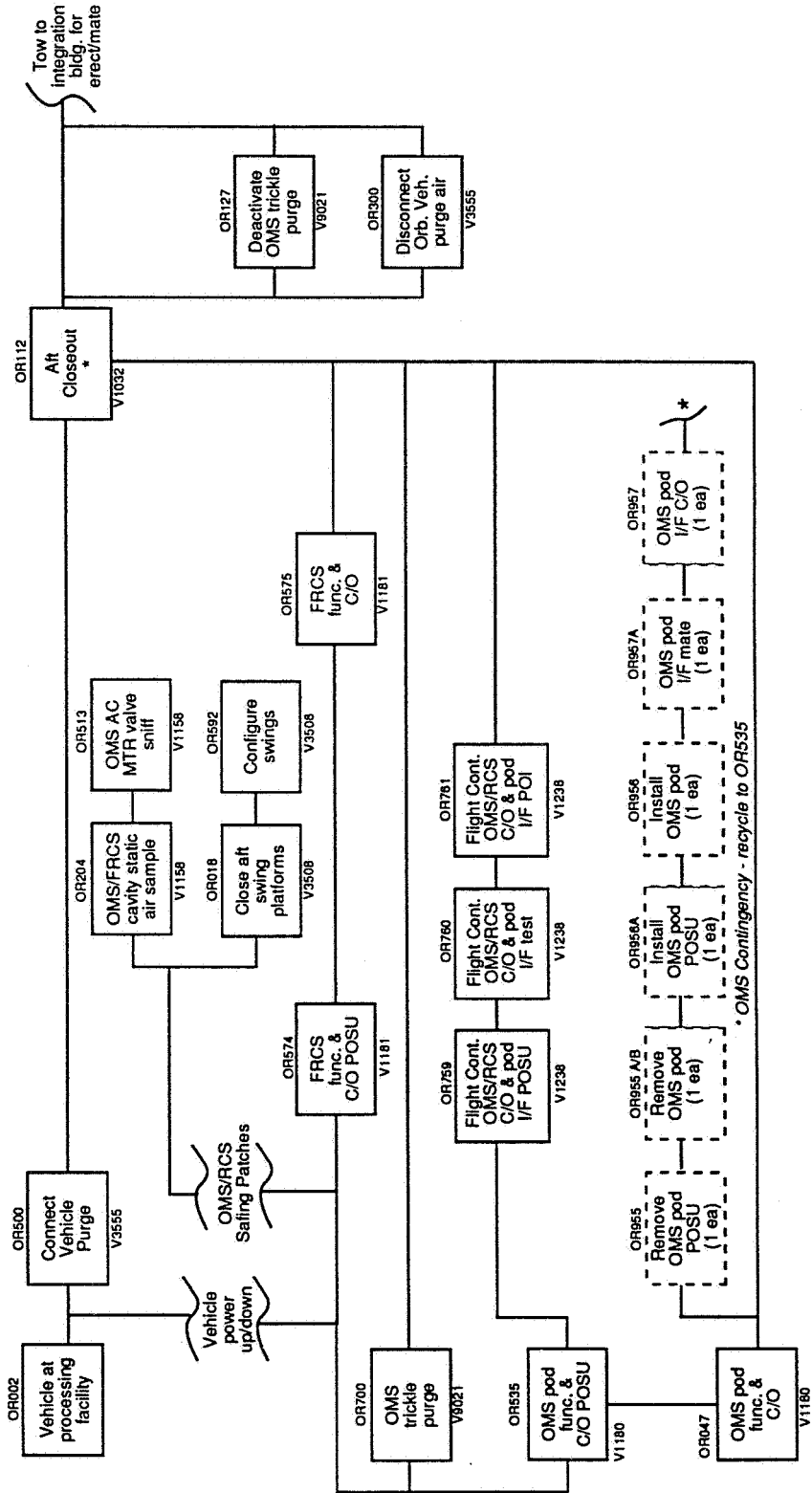

Figure 1-7. OEPPSS Generic Orbit Vehicle Propulsion System Logic Diagram

2.0 GROUND OPERATIONS PROBLEMS (VOLUME II)

This volume describes the major operations problems encountered in today's launch systems and how these problems have adversely affected our ability to achieve serviceability, reliability, and operability. Processing flight hardware for launch has been a very tedious and time-consuming task requiring large numbers of people operating sophisticated ground support equipment (GSE) to verify flight system readiness. This process is complex and involves numerous ground support systems. Many activities are "hands on" and serial in nature, which further complicates the checkout process. The ground support system themselves, providing services and commodities, also must be verified to ensure that every system is available and certified to support the checkout and test.

A typical illustration of the technical disciplines and operations support required for flight system checkout is depicted in Figure 2-1. An illustration of the large infrastructure of logistics, supplies, equipment, and facilities to support system checkout is depicted in Figure 2-2. Every different commodity required on the vehicle adds another tentacle to the operations support structure. It is, therefore, not surprising that the operations support for a complex launch system checkout will be manpower intensive, time-consuming, and costly; and a launch system that contains many separate, independent systems and interfaces simply exacerbates this problem.

A list of 26 major operations problems identified by the OEPSS study is given in Figure 2-3 generally in the order of operational impact or concern. Many of these problems are common to both reusable as well as expendable launch vehicles. A concise description of each problem and its operational impact is presented in this volume as follows:

- Operational impact
- Requirements background
- System description
- Operations problem description
- Brief physics of phenomena
- Potential options for solving problems
- Technology recommendation.

An example for the "closed aft compartment" operations concern is given on pages 2-5, 2-6, and 2-7. Another example for the "hydraulic system" operations concern, which is currently being successfully addressed by the ALS with the use of electromechanical actuators (EMAs), is given on pages 2-8, 2-9, and 2-10. Eliminating the operations problems, or concerns, or by applying lessons learned to solve these problems, will go a long way toward achieving the simplicity and operability needed to meet launch operations efficiency.

GROUND PROCESSING FOR FLIGHT IS COMPLEX AND DESIGN DRIVEN

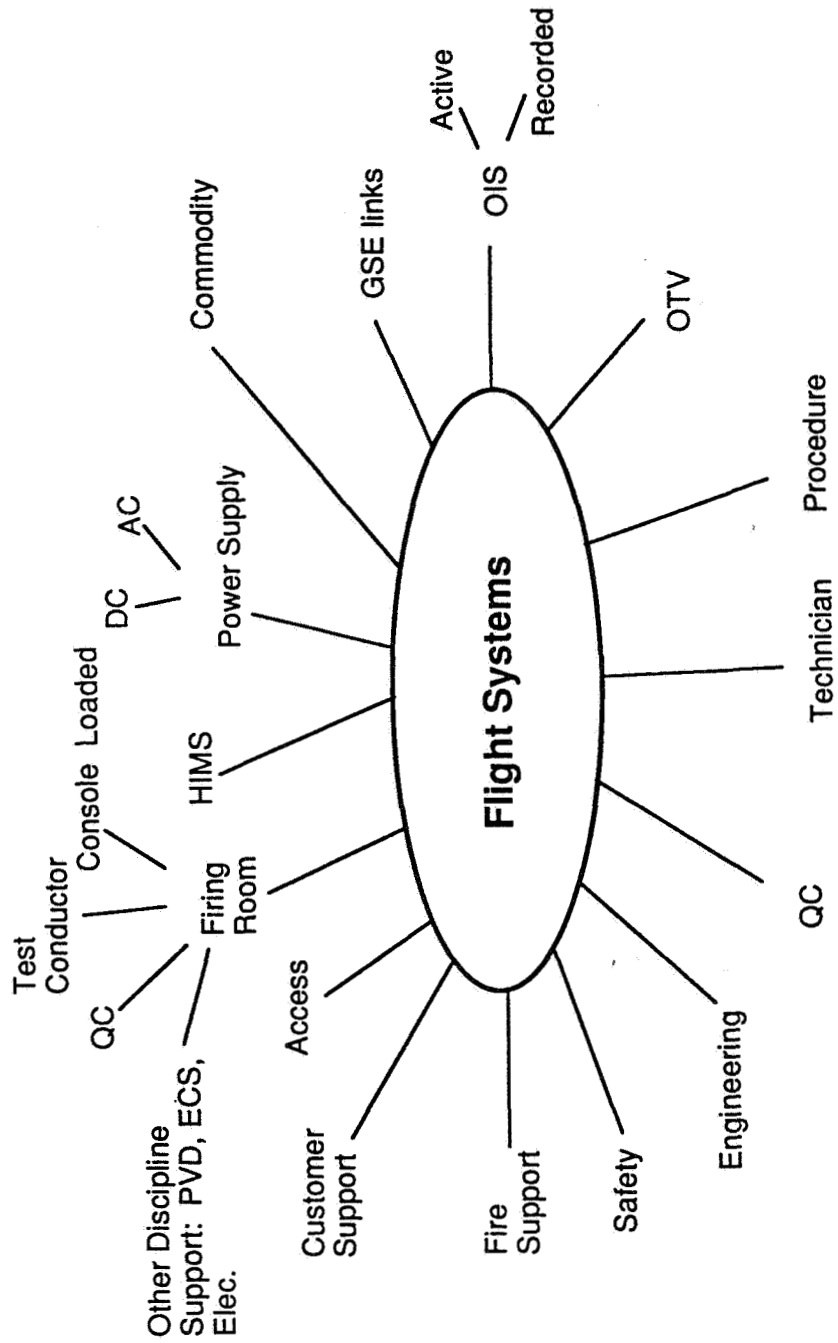

Figure 2-1. Launch System Operations Support

LAUNCH SUPPORT STRUCTURE IS COMPLEX AND DESIGN DRIVEN

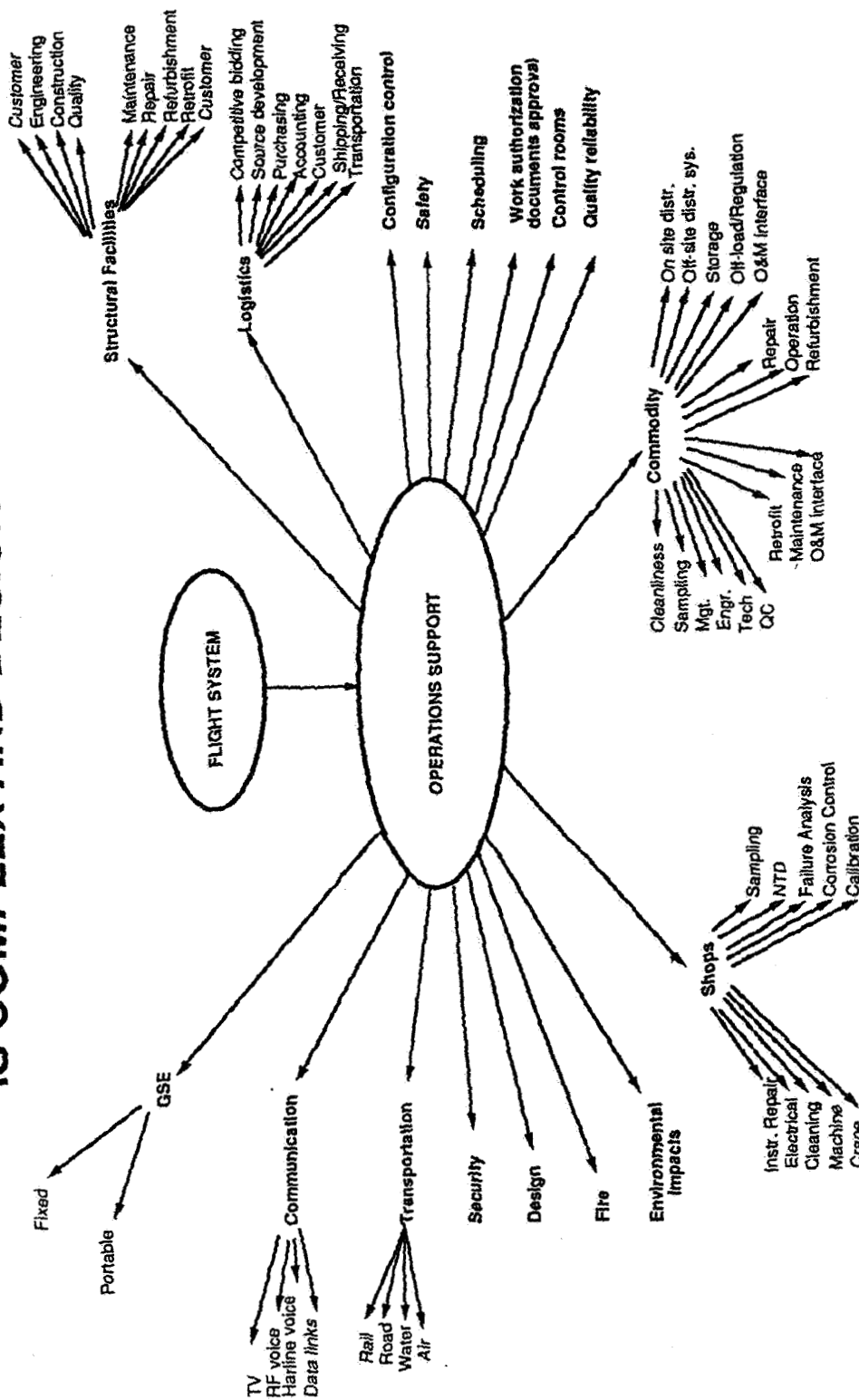

Figure 2-2. Launch Operations Support Structure

OEPSS IDENTIFIES MAJOR OPERATIONS CONCERNS AND IMPACTS

Causes and Effects

<u>No.</u>	<u>No.</u>
1	14
1A	15
2	16
3	17
4	18
5	19
6	20
7	21
8	22
9	23
10	24
11	25
12	26
13	

Closed aft compartments	Ordnance Operations
Fluid system leakage	Retractable T-O umbilical carrier plates
Hydraulic system (valve actuators and TVC)	Pressurization system
Ocean recovery/refurbishment	Inert gas purge
Multiple propellants	Excessive interfaces
Hypergolic propellants (safety)	Helium spin start
Accessibility	Conditioning/geysering (LO ₂ tank forward)
Sophisticated heat shielding	Preconditioning system
Excessive components/subsystems	Expensive commodity usage - helium
Lack hardware integration	Lack hardware commonality
Separate OMS/RCS	Propellant contamination
Pneumatic system (valve actuators)	Side-mounted booster vehicles (multiple stage propulsion systems)
Gimbal system	
High maintenance turbopumps	Component internal leakage

OEPSS Volume II - Ground Operations Problems

Figure 2-3. Ground Operations Problems

1.0 CLOSED AFT COMPARTMENTS, OEPSS CONCERN 1

1.1 OPERATIONAL IMPACT

The impact on ground operations caused by a propulsion system contained within a closed compartment is summarized in Figure 1-1.

1.2 REQUIREMENTS BACKGROUND

The need for structural efficiency is one of the factors leading to use of closed compartments in launch vehicles. Skin and stringer or monocoque type structures are strong and lightweight but, because their structural elements are large areas, tend to enclose volumes and form compartments. Where hazardous fluids exist within the enclosed volume, ground purging is usually required to preclude accumulation of these fluids as a result of possible leakage. This need for purging can then lead to further sealing of the compartment to control the purge process.

Closed compartments may also be used to protect components from main engine heat or other external environments. They also can be necessary to maintain pressure required for structural stability. The aft compartment of the STS Orbiter serves both functions as well as containing the inert purge.

1.3 SYSTEM DESCRIPTION

A typical ALS vehicle contains a closed engine compartment similar to that on the Orbiter for the same reasons. In addition, for the recoverable propulsion modules, the compartment protects the contained components and subsystems from sea water contamination. Closed compartments also are used in the intertank areas.

1.4 OPERATIONS PROBLEM DESCRIPTION

Closed compartments cause numerous ground operations problems because leakage of hazardous fluids is contained, because access is restricted, and because GSE requirements are made complex.

The fact that hazardous leakage can escape into a closed volume requires that volume be purged on the ground with an inert gas to preclude accumulation of hazardous fluids. A detection system is needed to ensure no dangerous buildup of gas. Both the purge and detection systems have vehicle hardware, ground interfaces, and ground support equipment. All necessitate maintenance, checkout, and servicing, which in turn demand a large staff of people to perform and support these functions. The inert purge leads to the very real possibility that personnel can inadvertently enter an environment that will not support life.

The restricted access caused by closed compartments also creates hazards for personnel. Injuries resulting from contact with hardware when working in tight areas are common, and the limited

- **Operational impacts**
 - Confinement of potential propellant leaks – criticality 1 failure
 - Requires inert purging during loading operations
 - Requires conditioned environment for personnel
 - Requires sophisticated hazardous gas detection system
 - Drives the requirement for sophisticated heat shielding
 - Inhibits proper access to components
 - Drives the requirement for specialized/dedicated GSE
 - Imposes manloading restrictions for confined space
 - Due to unnatural personnel passageways
 - Elevates potential for hardware damage
 - Additional interfaces required between vehicle and ground
 - Requires sophisticated ground support equipment
 - Environmental control system for personnel
 - Gaseous nitrogen regulation and distribution system
 - Must have redundant systems
 - Capable of local and remote operation
 - Requires an “army” for operation, maintenance, certification
 - Adds another function to the firing room operation
 - Tremendous risk to the safety of personnel and hardware
 - Drives many operations to be serial in flow
 - Drives need for LCC that could delay or scrub a launch
- **Potential options for consideration**
 - Aft area should be completely open – Ref. SII and SIVB vehicle configurations

D600-0011

Figure 1-1. Operational Impact of Closed Aft Compartments

access can preclude rapid evacuation in case of an emergency. Tight working areas also cause hardware damage, require serial work, and complicate LRU replacement.

In addition to the GSE needed to provide compartment purging and hazardous gas detection, the closed compartment requires that complex and expensive GSE be developed to support personnel access and permit LRU handling. Installation of this equipment, such as access platforms, can be difficult and time consuming and must be done with extreme care to prevent flight hardware damage.

1.5 BRIEF PHYSICS OF PHENOMENON

N/A

1.6 POTENTIAL OPTIONS FOR SOLVING THE PROBLEMS

The aft or boat-tail of the launch vehicle must be as open as possible, allowing any small amount of propellant leakage to escape to the atmosphere. Free access to the engines and other systems must be provided. A truss-work thrust structure might be ideal. Shielding from engine heat must not restrict general access. Closing of other compartments must be avoided where possible. Small compartments should be combined to form larger volumes where practicable.

1.7 TECHNOLOGY RECOMMENDATION

Develop arrangements of engines and structure that do not form closed compartments.

2.0 HYDRAULIC SYSTEMS FOR VALVE ACTUATORS AND TVC, OEPSS CONCERN 2

2.1 OPERATIONAL IMPACT

The impact on ground operations caused by hydraulic systems for a propulsion system is summarized in Figure 2-1.

2.2 REQUIREMENTS BACKGROUND

The use of hydraulic fluid as an operating medium for thrust vector control actuators and large rocket engine valve actuators has been common practice for most of our launch vehicles. Positive action, quick response, and relatively compact size for modulating control systems make hydraulic actuators very attractive, especially when there are large horsepower requirements for the actuator.

2.3 SYSTEM DESCRIPTION

The basic elements to provide the required hydraulic fluid pressure to the propulsion system components generally consist of a hydraulic pump, pump driver, hydraulic reservoir, hydraulic accumulator, hydraulic filters, control valves, and associated plumbing, instrumentation, and controls. Generally, the need to perform ground test and checkout dictates duplicate systems; therefore, a ground-based system as well as a flight system are needed. The requirements for redundancy in the hydraulic system essentially create the need for multiple and separate flight systems.

2.4 OPERATIONS PROBLEM DESCRIPTION

A hydraulic system represents another fluid distribution system that must be processed and maintained for flight operations. This involves distribution system leak checks, long periods of circulation for de-aeration/filtering, operations associated with fluid sampling and analysis, and functional checks of all control systems. In order to process the flight system, ground support equipment, generally consisting of all the basic hydraulic distribution system elements, must be duplicated to simulate pressure for the flight system checkout. The same operations and maintenance requirements are also required for the flight system. In the case of the Space Shuttle system, the operations problem is compounded by using hypergolic fueled auxiliary power units to drive the pumps. The use of a hypergolic fuel dictates that operations such as fueling the unit be conducted with only a limited number of personnel directly involved with the fueling operation and specially certified to work in self-contained atmospheric protective ensemble (SCAPE). This type of system dictates serial processing operations.

2.5 BRIEF PHYSICS OF PHENOMENON

Hydraulic actuation, whether for thrust vector control or valve control, requires that a nearly incompressible liquid be distributed from the area in which the liquid is stored and pressurized to the location of the actuator. The source of pressure, usually a positive displacement pump, may be powered by an electric motor from an engine-provided drive or by an auxiliary power unit. Actuators

- **Operational impacts**
 - Requires sophisticated ground support systems
 - Expensive pumping units/control systems
 - De-aerators/filters
 - High pressure piping systems
 - Both local and remote operating capability
 - “Army” to operate, maintain, sample, and calibrate system
 - Requires sophisticated flight hardware
 - Auxiliary power unit/pumping unit
 - Power units may demand lubrication equipment which may require cooling equipment
 - Control and filter systems
 - “Army” to operate, maintain, sample, and calibrate system
 - Requires long periods of circulation for de-aeration/filtering
 - Potential source of contamination for valve actuators
 - Another (2) fluid interfaces (minimum) between vehicle and ground
 - Depending on APU propellants, can force processing into periods of area clearing and serial operations
- **Potential options for consideration**
 - Electro-mechanical actuators

D600-0011

**Figure 2-1. Operational Impact of Hydraulic Systems
for Valve Actuators and TVC**

may be linear cylinders or rotary drives. Precise positioning of the actuator typically requires servo valves with position feedback for control. Because the servo valves have very small clearances between moving parts, careful control of fluid contamination is required.

2.6 POTENTIAL OPTIONS FOR SOLVING THE PROBLEM

To alleviate the problems associated with a hydraulic distribution system, the use of electro-mechanical actuators appears to offer the greatest potential for reducing operations cost associated with actuation systems. Electro-mechanical systems also offer the opportunity to automate completely the test, checkout, and verification of system integrity.

2.7 TECHNOLOGY RECOMMENDATION

Develop low cost, reliable, compact, electrical actuators for large cryogenic valves and thrust vector control devices that draw relatively low power.

3.0 OPERATIONS TECHNOLOGY (VOLUME III)

The operations concerns that have been identified in Volume II provided a basis for carefully examining the elements of the propulsion system that need to be addressed using existing technology or will require technology development. In the OEPSS study, the propulsion system appropriately includes not only the engines but the entire system producing vehicle thrust and control. Thus, the propellant tankage, the complete fluid management system, thrust structure, all the engine components and control system are considered as part of the propulsion system in the study. In this manner, artificial interfaces are eliminated. Artificial interfaces are an operations issue because the interfaces require extensive leak checks. Leak and functional testing of propulsion systems currently makes up a very large part of the launch processing and ground support operations.

The OEPSS study found that many operations concerns can be addressed by staying with existing technology and simply integrating and consolidating subsystems; however, new technology development is required to eliminate complex subsystems. For example, no technology is required to integrate the complex, multiple helium bottles and regulation systems into a single helium vessel with primary and backup regulation systems. This integration will simplify the launch system and check-out immensely. However, new technology will be required to remove helium completely from the launch system by designing-out the engine purge requirement.

To eliminate the operations problems associated with multiple propellants, hypergols, and separate OMS/RCS propulsion, new technology is needed to use a single common LOX/LH₂ propellant combination for all vehicle fluid systems including boosters, core engine, orbital maneuvering engines, attitude control thrusters and fuel cells. This is the only known propellant combination that can be integrated not only for all propulsion power, but can also be used for life support and thermal management. Moreover, it is readily available, relatively inexpensive, easily handled with existing procedures, environmentally acceptable, and provides the highest level of performance of any commonly used propellant combination. New technology is needed to eliminate the operations problems associated with propellant tank pressurization system of heat exchangers, valves, and long tubing runs. Leak checks of these systems are typically the most complex of the whole vehicle. Ground systems and umbilicals also require large amounts of manpower maintenance and are a critical function occurring near T-zero with critical launch commit criteria.

A list of 15 operations technologies identified by the OEPSS study that will enhance operational efficiency of the propulsion system significantly is shown in Figure 3-1. The manner in which each technology addresses the operations concerns contained in Volume II is shown by the matrix in Figure 3-2. Potential application of these technologies to future launch vehicles, to increase operability and reduce launch cost, is shown in Figure 3-3.

OEPPS IDENTIFIES TECHNOLOGY TO INCREASE OPERABILITY

- No purge pump seals
- No purge combustion chamber (start-shutdown)
- Oxidizer-rich turbine, LOX turbopump
- Hermetically sealed inert engine and tanks (prelaunch)
- Combined O₂/H₂, MPS, OMS, RCS, fuel cell, thermal control systems
- Flash boiling tank pressurization
- Low NPSH pumps
- Large flow range pumps
- Differential throttling
- Electric Motor Actuator (EMA)
- No leakage mechanical joints
- Automated self-diagnostic condition monitoring system
- Automated visual inspection
- Automated leak detection/location/discriminator
- Non-intrusive instrumentation

OEPPS Volume III - Operations Technology

Figure 3-1. Operations Technology

TECHNOLOGY REDUCES OPERATIONS CONCERNS AND IMPACT

OEPPS Concerns: ~~1~~ ~~2~~ ~~3~~ ~~4~~ ~~5~~ ~~6~~ ~~7~~ ~~8~~ ~~9~~ ~~10~~ ~~11~~ ~~12~~ ~~13~~ ~~14~~ ~~15~~ ~~16~~ ~~17~~ ~~18~~ ~~19~~ ~~20~~ ~~21~~ ~~22~~ ~~23~~ ~~24~~ ~~25~~ ~~26~~

Technology Needs*	OEPPS Concerns
• No leakage mechanical joint	1A 1 2 3 5 16 17 21
• Electric Motor Actuator (EMA)	1A 2 6 9 11 12 18 26
• Automated leak detection	1A 6 26
• Combined O ₂ /H ₂ systems (MPS, OMS, RCS, fuel cell, ECLSS)	4 5 8 9 10 18 23
• No purge pump seals	1A 8 17 18 22 26
• Automated, self-diagnostic, condition monitoring system	1A 1 6 13 26
• No purge combustion chamber (start-shutdown)	1A 8 17 18 22 26
• Flash boiling tank pressurization	1A 8 9 16 18 24 26
• Non-intrusive instrumentation	1A 6 8 18 24
• Automated visual inspection	6 13
• Differential throttling	1A 2 7 8 12
• Low NPSH pumps	13 16 19 21
• Large flow range pumps	8 13 19 21
• Oxidizer-rich turbine, LOX turbopump	8 13 17 22
• Hermetically sealed inert engine (prelaunch)	1A 8 17 18 22 24 26

Figure 3-2. Operations Concerns Addressed by Technology

OPERATIONS TECHNOLOGY APPLIES TO BOOSTER AND SPACE VEHICLES

Technology	Vehicle Systems			
	NLS	LRB	SSTO	Space
<ul style="list-style-type: none"> • No leakage mechanical joint • Electric Motor Actuator (EMA) • Automated leak detection • Combined O₂/H₂ systems (MPS, OMS, RCS, fuel cell, ECLSS) • No purge pump seals • Automated, self-diagnostic, condition monitoring system • No purge combustion chamber (shutdown) • Flash boiling tank pressurization • Non-intrusive instrumentation • Automated visual inspection • Differential throttling • Low NPSH pumps • Large flow range pumps • Oxidizer-rich turbine, LOX turbopump • Hermetically sealed inert engine (prelaunch) 	X	X	X	X
	X	X	X	X
	X	X	X	X
	X	X	X	X
	X	X	X	X
	X	X	X	X
	X	X	X	X
	X	X	X	X
	X	X	X	X
	X	X	X	X
	X	X	X	X
	X	X	X	X
	X	X	X	X
	X	X	X	X
	X	X	X	X
	X	X	X	X
	X	X	X	X
	X	X	X	X

Figure 3-3. Operations Technology Applied to Future Vehicles

Some of the technologies discussed in this volume are in various stages of development in on-going programs, such as ALS EMAs, or are a combination of technologies, rather than a discrete technology, such as differential throttling. The technologies described in more detail in this volume are the following:

- No-purge pump seals
- No-purge combustion chamber
- Oxidizer rich turbine, LOX turbopump
- Hermetically sealed inert engine
- Combined hydrogen systems
- Flash boiling tank pressurization system
- Low-NPSH pumps
- Large flow range pumps.

The technology descriptions highlight major areas requiring further study and provide a rough order of magnitude of the time frame in which the technologies could be developed. Also described are: (1) how each technology addresses operations concerns, (2) a recommended development plan, and (3) an approximate development schedule.

4.0 OEPSS DESIGN CONCEPTS (VOLUME IV)

The OEPSS study has identified ground operation problems that have limited our launch capabilities and prevented routine space flights. These problems are a direct result of the design approach used in our propulsion system designs. Unless these problems are fully confronted and their operational impacts circumvented, the design approach producing these problems will continue to persist. Perhaps the onus is on the operator, who has to contend with complex launch requirements, to convey adequate feedback to the designers and to recommend a design approach in terms understandable to themselves, the operators, that will achieve operational simplicity and meet ALS requirements for low cost routine space flight.

Thus, the OEPSS study undertook an effort to investigate several propulsion concepts that address the operations problems in its initial design. These design concepts are intended to depart from conventional approaches, to be thought provoking and to provide a fresh point of view. Although conceptual, they are tractable, viable engineering designs. They are "strawman" concepts, that may have self-evidential merit often overlooked and are offered for constructive critique. They are not "point designs," because concepts can take many final forms, but are intended to be intuitive, instructive, and illustrative. It is in the spirit of achieving a common goal with the designers that the propulsion design concepts described in the following sections are presented.

4.1 FULLY INTEGRATED PROPULSION CONCEPT

To achieve operational efficiency for a flight system, the design must be simplified to reduce operations support requirements. Since operational complexity is driven exponentially by the number of components and interfaces in the system, an example is used in the study to illustrate how the many duplicate components and subsystems, with all their interfaces, can be reduced significantly by "integrating" the system to function as a single engine with a minimum of components. The baseline ALS vehicle shown in Figure 4-1 was used as a reference for comparing the design of a conventional booster propulsion system in Figure 4-2 vis-a-vis with a more simple and operationally efficient design of an integrated booster propulsion module (BPM) in Figure 4-3, which utilizes the same state of the art as ALS.

The conventional propulsion system is a cluster of seven autonomous, gimbaling engines. There are as many components and subsystems as there are engines. In comparison, the integrated BPM is a static booster, eliminating gimbal actuators¹ (and associated hydraulic or electrical power system) and flexible propellant lines. It is a parallel manifolded system, with the turbopumps feeding all thrust chambers and operating independently of any given thrust chamber. The system, therefore, has an independent component-out (turbopump or thrust chamber out) capability where shutting down one component does not shut down other functioning components.

The integrated BPM also uses a single (rather than a multiple) subsystem for the following: the He pressurization system, the LOX pressurization system (heat exchanger), the avionics/control

¹Thrust vector control is provided by core propulsion module. See Volume IV, Section 1.2.2.5.

1989 ALS REFERENCE VEHICLE USED FOR EXAMPLE APPLICATION OF INTEGRATED BPM

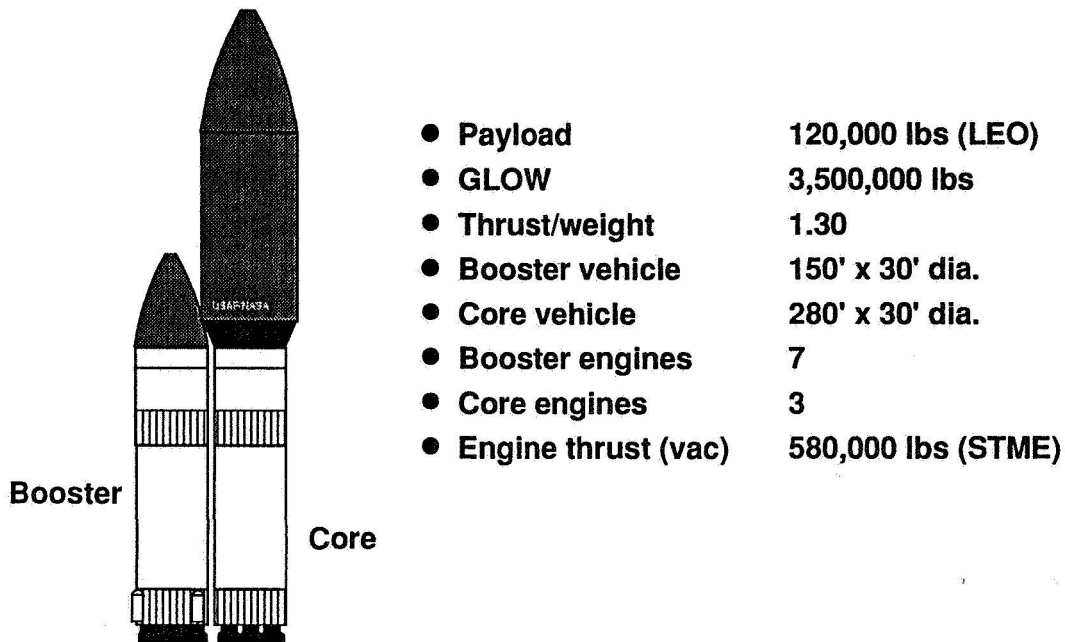

Figure 4-1. ALS Reference Vehicle

system, and the pneumatic control system. An additional thrust chamber was added to provide complete commonality with the core propulsion module. The added thrust chamber provides operating margin (normal operation at 85% rated thrust) and up thrust capability. The simplicity of the integrated BPM is described below. It also has nearly one-half the number of turbopumps² and propellant lines as in the conventional system:

- Single He-Pressurization System
- Single LOX-Pressurization System (HX)
- Single Control System
- No artificial interfaces
- No flexible propellant lines
- No gimbal actuators
- 50% less propellant lines, T/Ps, GGs
- Operating margin (normal operation at 85% thrust)

²The turbopumps are designed for twice rated STME thrust, robust in design, and operate at 90% rated speed (operating margin). See Volume IV, Sections 1.3.1, 1.4.2, and 1.6.1.

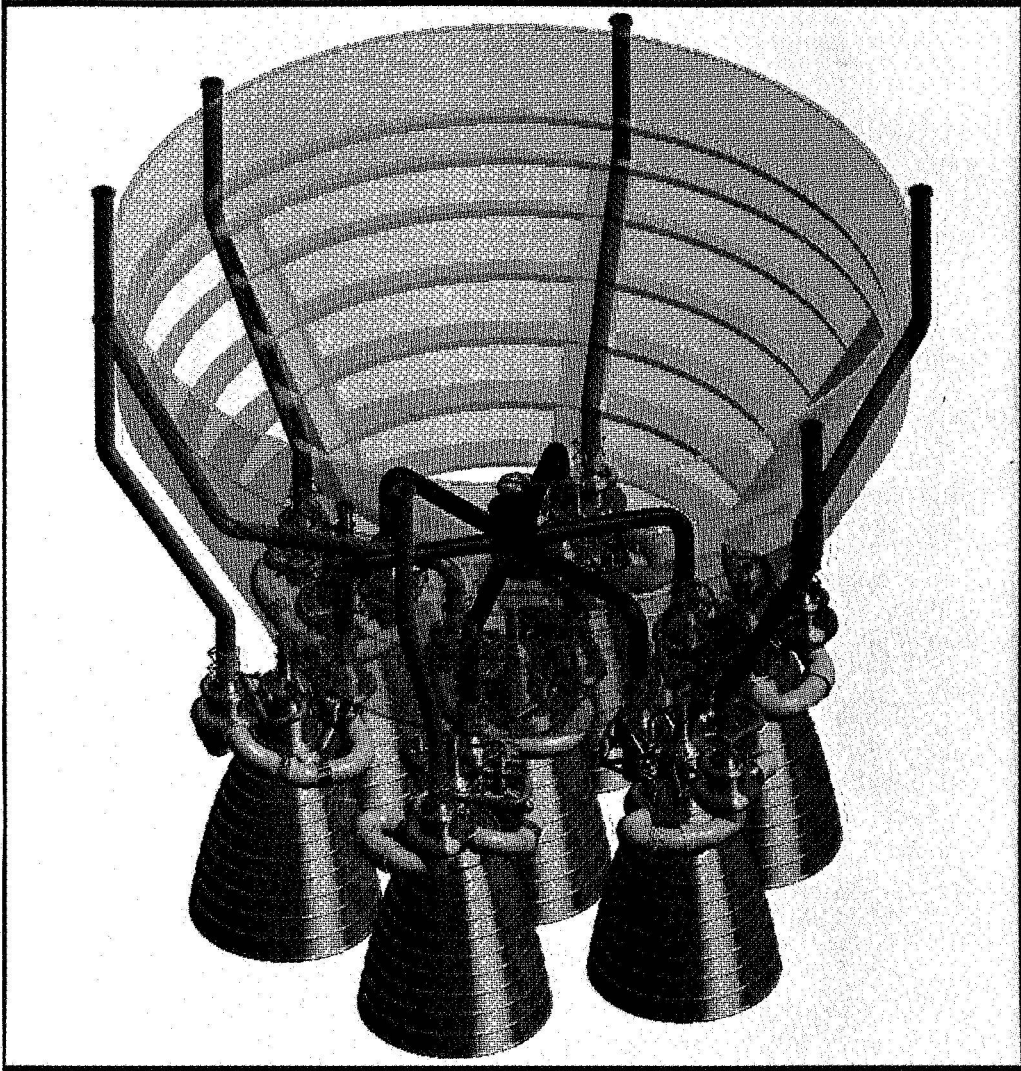

Figure 4-2. Conventional Booster Propulsion System

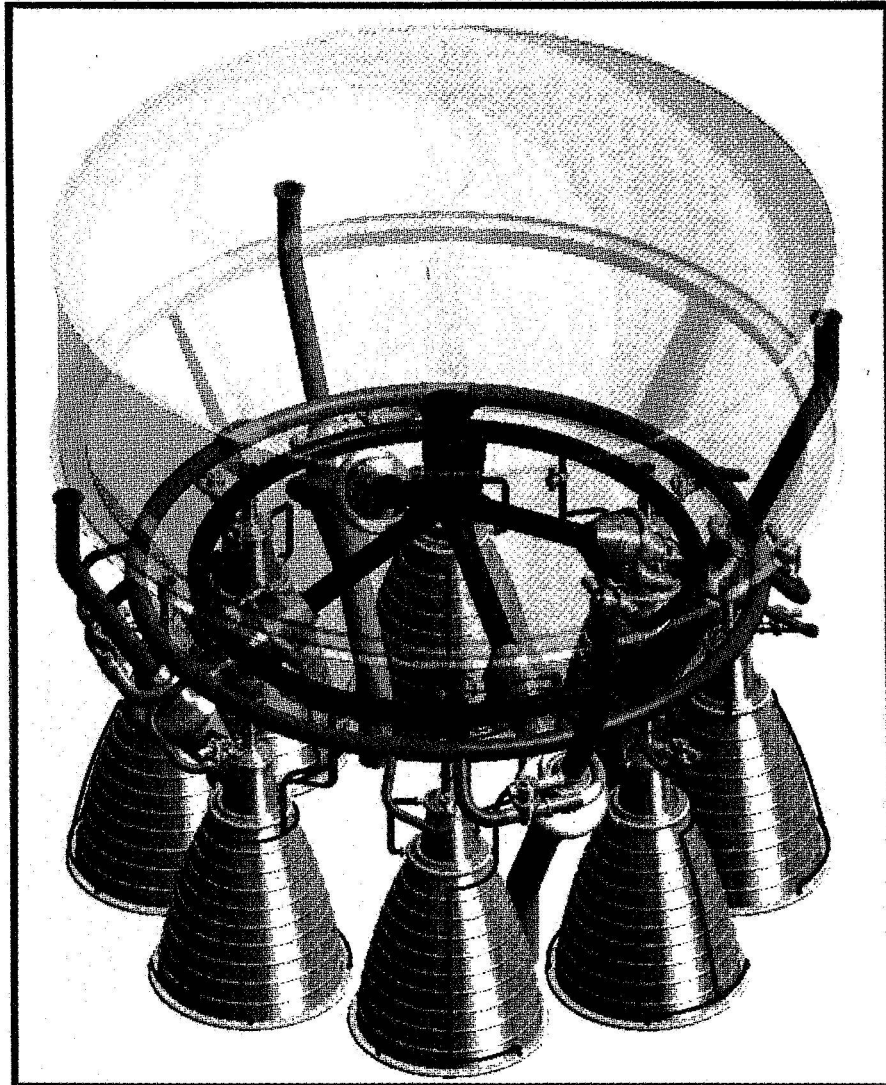

Figure 4-3. Fully Integrated Booster Propulsion Module

A comparison³ between the two propulsion systems is schematically illustrated in Figure 4-4 where the substantial reduction in the number of major components achieved by the integrated BPM is markedly apparent. The schematic also illustrates the engine-out condition for the autonomous system where for a single-string system all components (both good and bad) within the given engine are shut down. For the integrated system the failed component is simply isolated from the system by isolation valves while the remaining components continue to operate at its design operating condition (100% rated thrust).

Another comparison between the two systems is given in Table 4-1 in terms of relative system reliability, engine-out capability, operability, relative system cost, and relative system weight. Basic STME engine data was used. The potential advantages of the integrated BPM are rather striking. The system reliability is significantly higher. It can accept two independent component-out conditions and meet mission requirements (the conventional system with two engine-out will have lost its mission). It has lower engine unit cost and lower system weight. And, finally, by virtue of a significant reduction of parts, it has greater operability and lower operations cost by at least a factor of three or greater.

Another feature of the integrated BPM is that it is basically made up of identical engine-elements. Each engine-element contains a gas generator, a turbopump set, and two thrust chambers

FEWER COMPONENTS/SUBSYSTEMS/INTERFACES INCREASES OPERABILITY REDUCES GROUND OPERATIONS

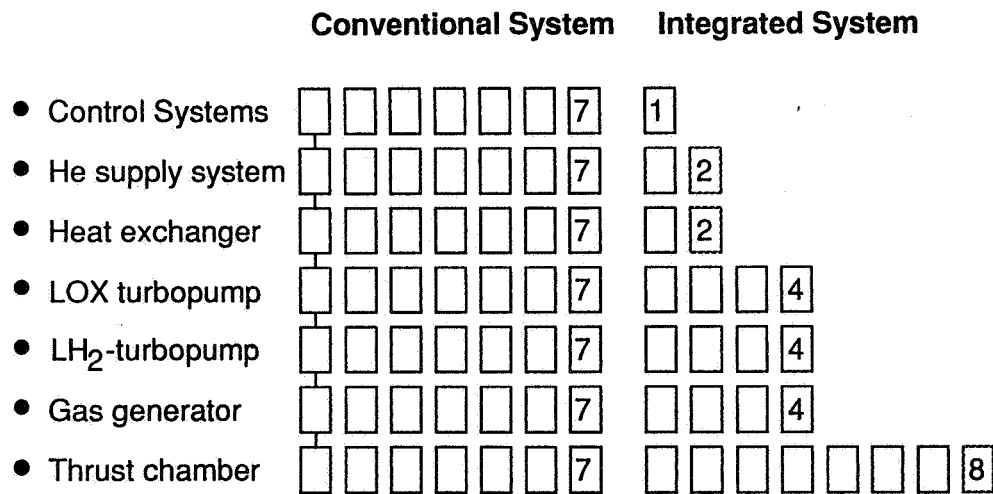

Figure 4-4. Schematic Comparison of Conventional and Integrated Propulsion Systems

³One additional He supply system and heat exchanger are arbitrarily added to the integrated system for the comparison.

Table 4-1. Comparison of Conventional and Integrated Propulsion System Design Features

INTEGRATED PROPULSION MODULE IS RELIABLE AND LOW COST

Factor	Separate	Integrated
● Higher reliability	0.988*	0.993*
T/C and T/P out	0**	0.999**
● Lower engine (T/C) cost, \$M	2.67	1.83
● Less number of parts	169	111
● Lower potential weight, lbs.	87,340	76,058
● Lower operations cost	1	1/3

* No engine-out capability

** With T/C and T/P - out capability

as seen in Figure 4-5. Multiple engine-elements are packaged with the propulsion subsystems, which include the electrical power, pneumatics, control/avionics and propellant feed system, to form a propulsion module. The ALS core propulsion module is simply made up of two of these engine-elements. (see Figure 4-6.) In fact, different propulsion modules can be made up by these basic engine-elements to meet a range of payloads from 60,000 to 300,000 lb. This is illustrated for a typical ALS family of vehicles in Figure 4-7 and Table 4-2.

A major finding from this study, albeit top level, is the fact that in order for future propulsion systems to achieve high operability, i.e., substantially higher than what we have today, the design must avoid a complex system by having fewer parts and components and fewer interfaces, subsystems, and fluid systems; and the design must consider the total propulsion system as a single functional engine unit, rather than a grouping of many separate engines requiring artificial interfaces and duplicate components and subsystems. The integrated BPM design concept is also seen in Figure 4-8 to address, directly and indirectly, seven of the top ten major operation issues described in Volume II as major operations concerns.

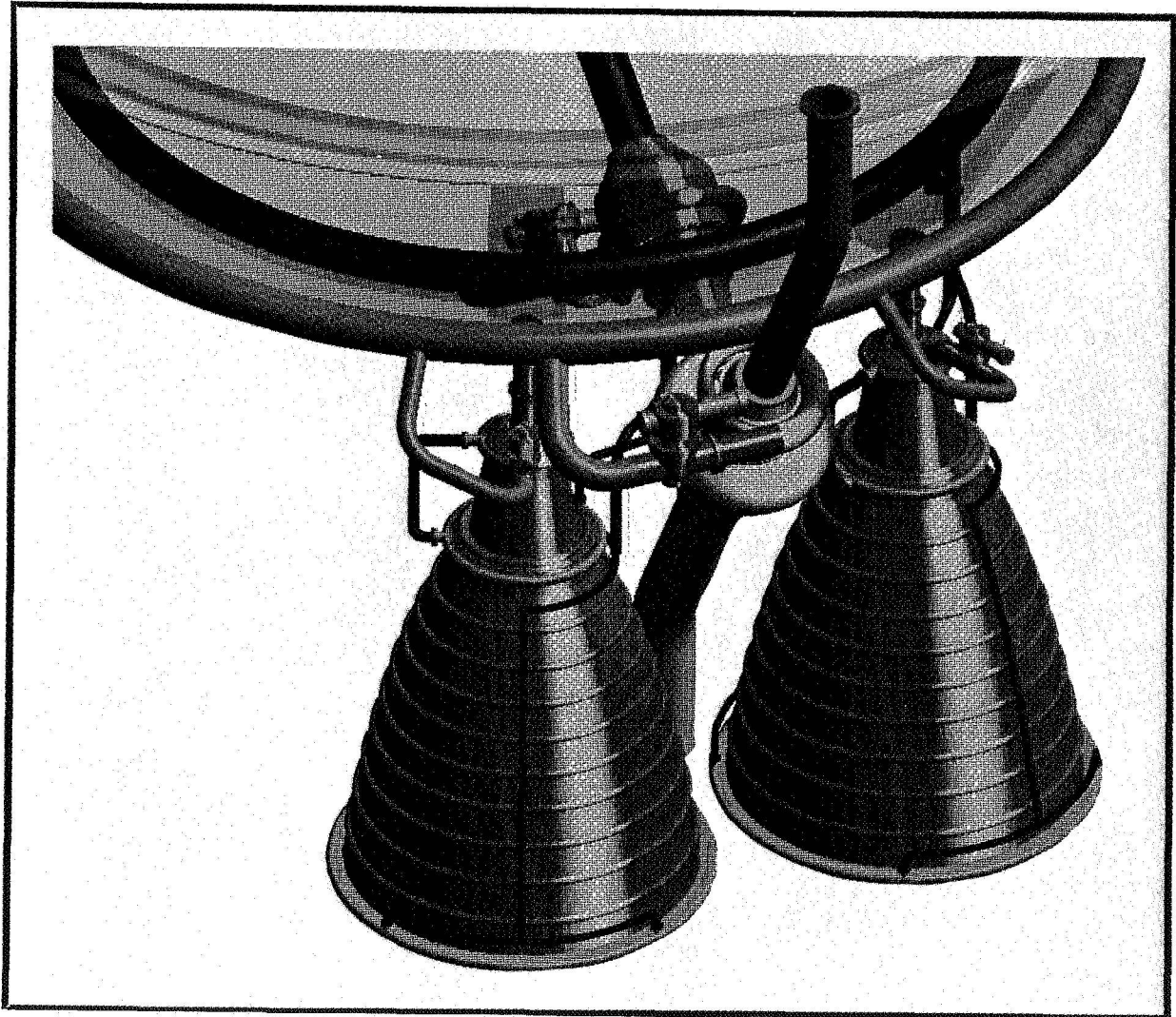

Figure 4-5. Integrated Engine-Element

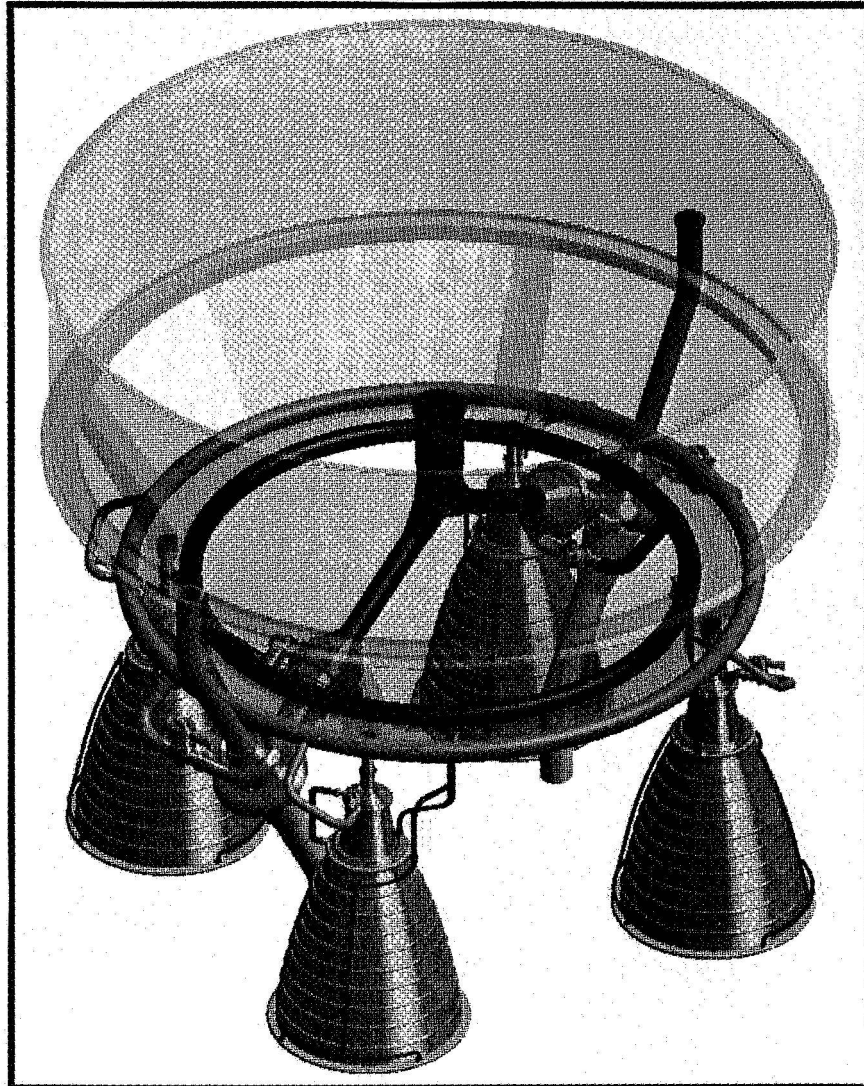

Figure 4-6. ALS Integrated Core Propulsion Module

PAYLOAD CAPABILITY USING INTEGRATED ENGINE ELEMENTS

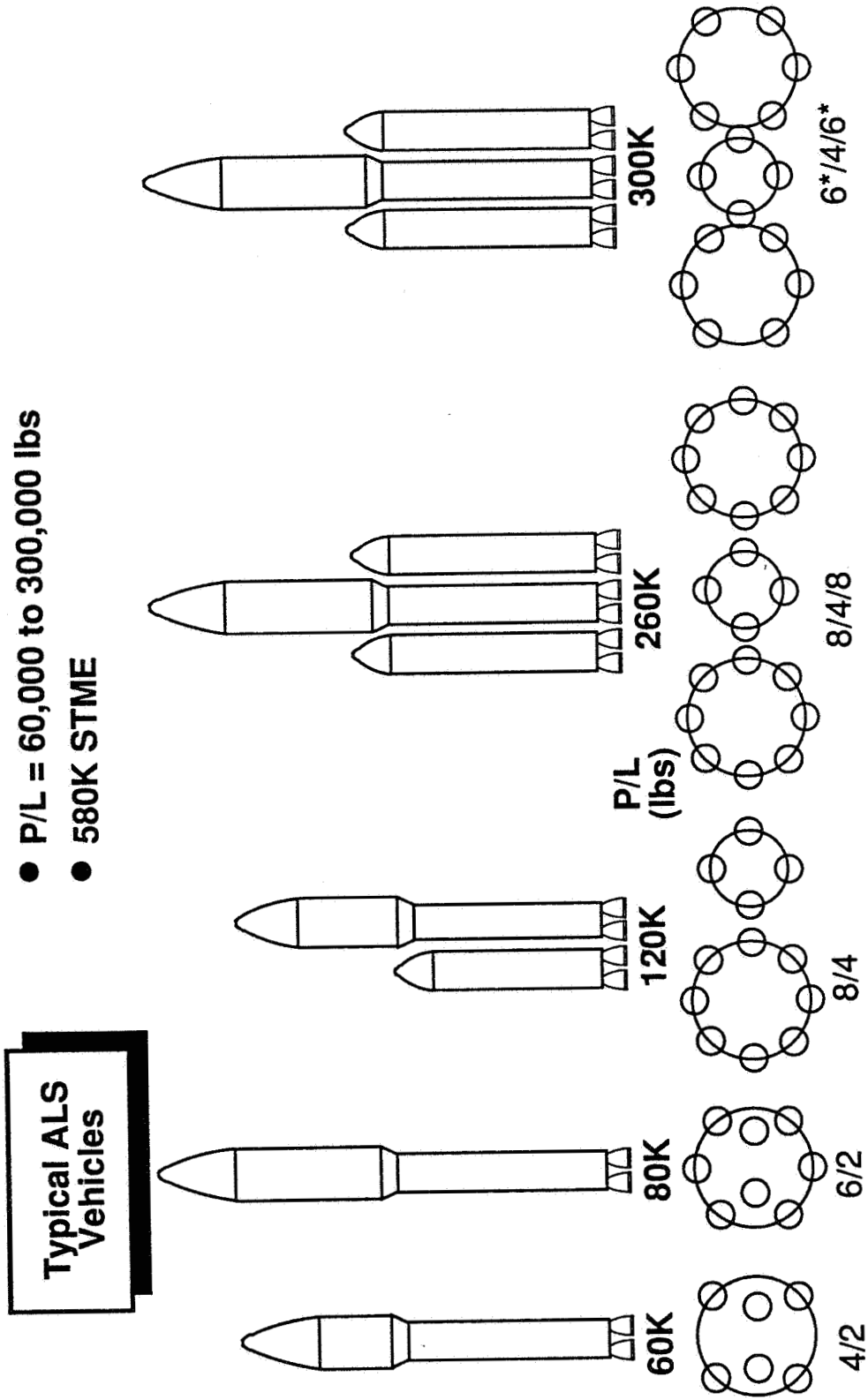

Figure 4-7. Payload Capabilities of Integrated Propulsion Systems

Table 4-2. Integrated Propulsion Systems Synthesized by Engine-Elements

- P/L = 60,000 to 300,000 lbs
- STME 580 Klbs thrust chambers

Integrated Engine:	Thrust Chambers		Payload Capability, lbs				
	Booster	Core	60K	80K	120K	260K	300K
3 - Elements*	4	2	X				
4 - Elements*	6	2		X			
6 - Elements**	8	4			X		
10 - Elements***	8/8	4				X	
8 - Elements****	6/6	4					X

- Staged vehicles
- ** Side-mounted booster vehicle
- *** Two side-mounted LRBs
- *** HLLV configuration, 650K STME

No.

- ① Closed aft compartments
- ② Hydraulic system (valve actuators and TVC)
- ③ Ocean recovery/refurbishment
- ⑥ Accessibility
- ⑦ Sophisticated heat shielding
- ⑧ Excessive components/subsystems
- ⑨ Lack hardware integration
- ⑪ Pneumatic system (valve actuators)
- ⑫ Gimbal system
- ⑬ High maintenance turbopumps
- ⑱ Excessive interfaces
- ⑳ Lack hardware commonality

Figure 4-8. Operation Concerns Addressed by Integrated BPM

4.2 LOX TANK AFT PROPULSION CONCEPT

A launch vehicle with the main liquid oxygen tank located forward in the vehicle creates complex operational requirements and causes major operational problems or concerns that severely impact launch operations. These problems include (1) geysering in the long propellant lines, (2) propellant conditioning to meet engine start requirements, (3) difficult checkout and servicing of long feed lines requiring a service tower, (4) higher ground transfer pressures for loading propellants to the elevated forward tank, and (5) operation of a helium-bubbling system to prevent geysering. These problems also create a need for complex system of ground support facilities and personnel. Since propellant tanks should be considered as an integral part of the total propulsion system, their configuration must also be optimized together with the propulsion system to eliminate serious and costly operational requirements.

To avoid the complex operations problems described above, several alternative propellant tank concepts were studied wherein the LOX tank is located aft or in parallel with the fuel tank to lower and shorten the LOX lines. Thus by shortening the lines, propellant conditioning of long lines would be eliminated and a greatly simplified chill procedure would eliminate the potentially more destructive problems of geysering and POGO. The four tank concepts studied are illustrated in Figure 4-9. The results indicate that the LOX tank aft (Figure 4-9 [a]) and parallel tanks (Figure 4-9 [b]) are comparable to the ALS baseline in terms of weight and cost; however, the concentric tanks (Figure 4-9 [c]) and torodial tank (Figure 4-9 [d]) would be higher. The use of the LOX tank aft concept has precedence in the Jupiter, Centaur, Saturn S-IV, Saturn S-IVB, and Saturn S-II vehicles, and parallel tanks have been used in Saturn IB, so they are viable concepts.

All the tank concepts resulted in a lower vehicle center of gravity than the ALS baseline. This in turn results in a shorter control moment for thrust vector control and greater shift in center of gravity during engine burn. However, analysis shows that for the ALS side-mounted vehicle configuration with the booster engines canted 10 deg, the maximum gimbal angle requirement, with engine-out and at booster separation, is approximately 16 deg. For the core vehicle, after booster separation, the maximum gimbal angle requirement with engine-out is decreased to 8 deg. Although these tank concepts require higher gimbal angles than the ALS baseline controllability, they are not beyond the capability of a good integrated propulsion system design. Changing from a side-mounted booster to a more symmetrical vehicle configuration will greatly simplify the control problem and, indeed, if a static booster is used, the booster engine gimbaling requirement would be eliminated.

4.3 AIR-AUGMENTED, ROCKET ENGINE NOZZLE AFTERBURNING PROPULSION CONCEPT

The air-augmented rocket engine is another propulsion concept investigated in the OEPSS study, not for its combined-cycle, high specific impulse performance, but from the standpoint of reducing operational requirements. The amount of oxygen carried by the rocket vehicle to fly through the atmosphere is as much as 40 to 50% of the vehicle gross lift-off weight (GLOW). If the atmosphere oxygen can be used to burn with the fuel-rich rocket engine exhaust for thrust, then the

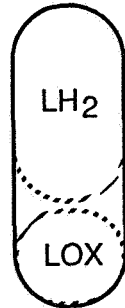

- Short LOX feed lines greatly reduce or eliminate geysering and pogo problems and associated systems
- Smaller LOX tank results in shorter feed lines from forward tank
- Weight reduction of feed lines, LH₂ tank and intertank structure
- Large reduction in propellant conditioning required for LOX loading and engine start on LOX side
- Reduced control authority from aft C.G. location
- Cost similar to ALS vehicles

(a) LOX Tank Aft

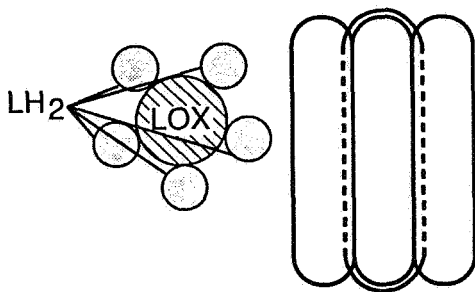

- Both LOX and LH₂ feed lines short
- Greatly reduce or eliminate pogo and geyser problems and associated systems
- Large reduction in propellant conditioning required for propellant loading and engine start
- Tank weight increased (≈10%)
- Large change in C.G. locations (travel) during burn increases engine gimbal requirements
- Higher total tank set cost may be offset by easier fabrication and transportation of individual tanks

(b) Parallel Tanks

Figure 4-9. LOX Tank Concepts

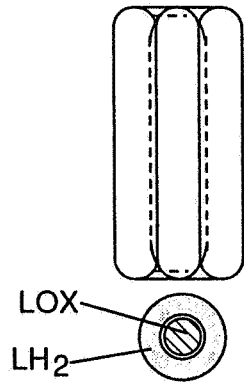

- Both LOX and LH₂ feed lines short
- Greatly reduce or eliminate pogo & geyser problems and associated systems
- Large reduction in propellant conditioning required for loading and engine start
- Tank weight increased ($\approx 10\%$)
- Large change in C.G. locations (travel) during burn increases engine gimbal requirements
- Fabrication problems can increase costs
- Thrust loads carried by outer tank

(c) Concentric Tanks

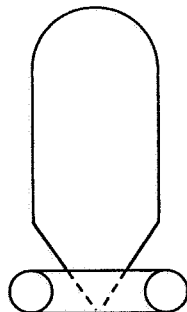

- Both LOX and LH₂ feed lines short
- Greatly reduce or eliminate pogo & geyser problems and associated systems
- Large reduction in propellant conditioning required for loading and engine start
- Tank weight increased ($\approx 10\%$)
- Reduced control authority from aft C.G. location
- Fabrication problems can increase costs
- Efficient thrust load path LOX tank not involved

(d) Toroidal Tank

Figure 4-9. LOX Tank Concepts (Continued)

amount of liquid oxygen that must be carried by an LOX/LH₂ vehicle will be greatly reduced. The reduction in liquid oxygen handling on a smaller vehicle will greatly simplify ground operations and reduce ground support equipment and facility requirements. Indeed, if thrust augmentation can reduce a multistage to a single-stage vehicle, the doubling and tripling ground operations for multiple boosters and core would be avoided. The air-augmented rocket concept is particularly attractive for a single stage-to-orbit (SSTO) vehicle application.

The SSME exhaust plume study found that approximately 50% of the exhaust excess hydrogen is burned by mixing and combustion of supersonic exhaust gas with ambient air in about 5 diameters downstream of the nozzle. Previous experimental studies by Martin Marietta Company showed that as much as 14% thrust augmentation at lift-off with a hydrogen peroxide rocket engine⁴ and 55% at Mach 2.0 with a LOX/RP-1 rocket engine⁵ were obtained by using a simple divergent ejector shroud over the engine nozzle. The purpose of the OEPSS air-augment study, therefore, is to investigate the feasibility of an operationally efficient, air-augmented ejector for a LOX/LH₂ rocket engine in light of previous work and in view of more current state-of-the-art data.

The focus of the air-augmented study is to achieve thrust augmentation with a LOX/LH₂ engine using the simplest, fixed-geometry, passive ejector system. A simple ejector/rocket propulsion system concept is illustrated in Figure 4-10. The conventional bell nozzle is surrounded by an ejector shroud extension that captures, directs, and mixes atmospheric air with the rocket nozzle exhaust gas. In the process of ingestion compression, mixing, combustion of air and fuel-rich exhaust, and expansion in the divergent shroud, augmented thrust is obtained.

For the top-level conceptual design study conducted on the air-augmented, ejector/rocket concept, the ALS vehicle and flight trajectory were used to determine the ejector geometry for the LOX/LH₂ STME engine. In order to define an ejector geometry envelope suitable for operation over a range of flight Mach numbers from zero to 2.0, optimum point-design ejector geometry was determined for static condition and for Mach numbers of 0.45, 0.80, 1.0, and 2.0. These optimum geometries provide maximum thrust augmentation at their respective point-design flight speed but will result in lower thrust augmentation at other flight speeds. A mission analysis was performed for the point-design ejectors with the ALS vehicle and flight trajectory, and the overall effective thrust increase is traded off with the increase in ejector drag and weight. The best ejector geometry and point-design flight speed is one which results in maximum payload increase or gross lift-off weight decrease for the ALS baseline vehicle. Unlike the rocket engine, the ejector thrust depends on altitude and flight speed; therefore, the initial ALS rocket trajectory was iterated several times to converge on a better ejector performance match with the air breathing portion of the trajectory in terms of altitude, thrust, and flight Mach number.

⁴A. J. Simonson and J. W. Schmeer, "Static Thrust Augmentation of a Rocket-Ejector System with a Heated Supersonic Primary Jet," NASA TND-1261, Langley Research Center, May 1962

⁵E. A. Mossman, R. L. Chapman, and R. C. Rozycki, "Experimental and Theoretical Investigation of the Rocket Engine Nozzle Ejector (RENE) Propulsion System," AFRPL TR-65-66, April 1965

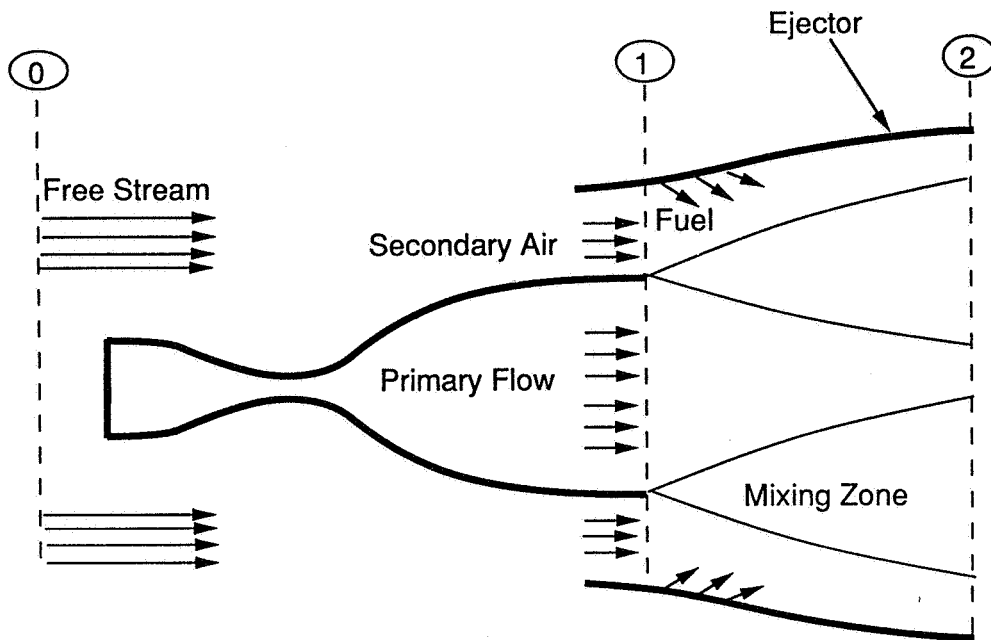

Figure 4-10. Rocket Engine Air-Augmented Afterburning Concept

For the ejector design described in Table 4-3, preliminary results indicate that the thrust augmentation obtained with the STME engine was 12% at sea level static condition, 18% at $M_o \cong 1.0$ and 8% at flight $M_o = 2.0$. This increased performance, when applied to the propulsion system for

Table 4-3. Ejector Design Parameters

Flight Mach number, M_o	= 0 to 2.0
Ejector area ratio, $\left(\frac{A_2}{A_s}\right)$	= 1.60
Length/diameter ratio, (L/D)	= 1.0
Inlet area, (A_2)	= 80 ft ²
Mass flow ratio, $\left(\frac{\dot{m}_s}{\dot{m}_p}\right)$	= 3.0
Point design M_o	$\cong 1.0$

D600-0011

the ALS baseline vehicle (which has a payload of 120,000 lb), is equivalent to increasing its payload capability by 16.6% or to decreasing its gross lift-off weight by 9.6% for the same payload. Based on the sensitivity factor developed for the ALS baseline vehicle ($\Delta PL/\Delta I_s \cong 800 \text{ lb/s}$), the 16.6% increase in payload capability is equivalent to an increase in engine specific impulse performance of $\Delta I_s = 24 \text{ s}$. In applying the air-augmented concept to a cluster of engines, a single shroud is used for the cluster to achieve equivalent performance. Vehicle/engine integration and other design issues are discussed in Volume IV. Later studies will also include the effect of fuel addition to increase net thrust augmentation.

5.0 OEPSS FINAL BRIEFING (VOLUME V)

This volume consists of a final briefing on the OEPSS study summarizing the activities and results of the first-year effort. This briefing was presented at NASA MSFC, Huntsville, AL, and is being made a part of the OEPSS Data Books.

D600-0011/sjh

RI/RD90-149-5

5-1